

**AALIM MUHAMMED SALEGH COLLEGE OF ENGINEERING**

**DEPARTMENT OF MECHANICAL ENGINEERING**

**ME8694 HYDRAULICS AND PNEUMATICS**

**YEAR: III**

**SEMESTER: VI**

**ANNA UNIVERSITY QUESTION PAPER SOLVED 2MARKS**

**UNIT-I**

**FLUID POWER PRINCIPLES AND HYDRAULIC PUMPS**

**PART-A**

**1. Write about positive displacement pumps? (NOV/DEC2011)**

Positive displacement pumps have the internal working elements which make a very, close fit together so that there is very little leakage (or) slippage between them. This type of pumps ejects a fixed quantity of liquid into the hydraulic system per revolution of the' pump shaft.

**2. Define absolute viscosity and kinematic viscosity. Nov/Dec2011**

Absolute Viscosity is the force needed by a fluid to overcome its own internal molecular friction so that it can flow. In the field of fluid mechanics absolute viscosity is also known as dynamic viscosity.

Kinematic viscosity is a measure of a fluid's internal resistance to flow under gravitational forces. It is determined by measuring the time in seconds, required for a fixed volume of fluid to flow a known distance by gravity through a capillary within a calibrated viscometer at a closely controlled temperature.

**3. List the primary function of hydraulic fluid. Nov/Dec2012**

The major function of a hydraulic fluid is to provide energy transmission through the system which enables work and motion to be accomplished. Hydraulic fluids are also responsible for lubrication, heat transfer and contamination control.

**4. List the application of Fluid power in Agriculture and Aviation industries. May/June2013**

1. **Agriculture:** Tractors and farm equipments like ploughs, mowers, chemical sprayers, fertilizer spreaders, hay balers
2. **Aviation:** Fluid power equipments like landing wheels on aeroplane and helicopter, aircraft trolleys, aircraft engine test beds.

**5. Write the procedure to calculate pressure drop in hydraulic circuits system May/June2013**

Pressure drops are also due to valves, expansions, contractions, bends, elbows, tees and pipe fittings. The losses in valves and fittings in hydraulic systems are frequently computed in terms of equivalent length of hydraulic tube. Equivalent lengths can then be substituted in Darcy-Weisbach equation to solve for total pressure loss in the system. The formula for computing equivalent length is

$$\text{Equivalent length } L_e = \frac{KD}{f} \quad K = \text{factor value of fittings}$$

## **6. Why screw pumps generate less noise while running? May/June 2013**

Conventional, high-pressure gear pumps are noisy because they trap and compress fluid between gear teeth as it rotates. Screw pumps typically run silently with low pulsations, for low to medium, but not high-pressure duty.

## **7. Differentiate fixed and variable displacement pumps May/June2013**

Simple, fixed-displacement pumps are perfect for single jobs that need to be repeated indefinitely over long periods of time, variable-displacement pumps can be used to power a wider variety of tools, but require more expense and more attention.

## **8. List the basic arrangements in hydrostatic drives. May/June2013**

The operating principle of hydrostatic transmissions (HSTs) is simple: A pump, connected to the prime mover, generates flow to drive a hydraulic motor, which is connected to the load. If the displacement of the pump and motor are fixed, the HST simply acts as a gearbox to transmit power from the prime mover to the load. Most HSTs, however, use a variable-displacement pump, motor, or both so that speed, torque, or power can be regulate.

## **9. What is the importance of Reynolds number? May/June2014**

The Reynolds (  $Re$  ) number is a quantity which engineers use to estimate if a fluid flow is laminar or turbulent. This is important, because increased mixing and shearing occur in turbulent flow. This results in increased viscous losses which affects the efficiency of hydraulic machines.

**10. Write the Darcy –Weisbach equation. May/June2014, April /May2015**

The energy loss due to friction in a hydraulic system results in a loss of potential energy. This potential energy loss leads to a pressure drop or head loss in the system. Pressure or head loss due to friction in pipes carrying fluids are derived using the Darcy-Weisbach Equation.

$$H_L = f \left( \frac{L}{D} \right) \left( \frac{V^2}{g} \right)$$

$H_L$  – Head Loss

$V$  – Velocity of Flow

$f$  - Friction Factor

$g$  – Acceleration due to gravity

$L$  - Length of pipe

$D$  – Inner Diameter

**11. What is a balanced vane pump? May/June2014**

In balanced vane pump, there are two inlet and outlet ports which are diametrically opposite to each other. Because the pressure ports are opposite to each other, a complete hydraulic balance is achieved.

**12. State any four causes for hydraulic system breakdown. May/June 2012**

Hydraulic Fluid Contamination. A leading cause of many hydraulic pump failures is hydraulic fluid contamination

- Heat-Aging
- General Abrasion
- Incorrect Insertion Depth
- Get Help Fast with Air-Way

**13 .Write any four application of fluid power system (April/May2015, April/may2008)**

Food and Beverage: All types of food processing equipment, wrapping, bottling

Foundry: Full and semi automatic molding machines, tilting of furnaces, die casting machines

Glass Industry: Vacuum suction cups for handling

Material Handling: Jacks, Hoists, Cranes, Forklift, Conveyor system

**14. Write about positive displacement pumps? April/May2015**

Positive displacement pump (PDP) is a type of pump in which a moving fluid is captured in a cavity and then discharges that fixed amount of fluid. Some of these pumps have expanding cavity at the suction side and a decreasing cavity at the discharge side.

**15. What is viscosity index? (April/May2008)**

The viscosity index (VI) is an arbitrary, unit less measure of the change of viscosity with temperature, mostly used to characterize the viscosity-temperature behavior of lubricating oils. The lower the VI, the more the viscosity is affected by changes in temperature.

**16. Name any four hydraulic fluids that are commonly used. (April/May2008)**

1. Mineral hydraulic oil (petroleum base).
2. Phosphate ester based synthetic hydraulic fluids.
3. Vegetable hydraulic oils
4. Water glycol synthetic hydraulic fluids

### **17. What is pump cavitations? How can you avoid it? (April/May2008)**

Cavitation is the formation of bubbles or cavities in liquid, developed in areas of relatively low pressure around an impeller. The imploding or collapsing of these bubbles triggers intense shockwaves inside the pump, causing significant damage to the impeller and/or the pump housing.

1. Lower the temperature.
2. Raise the liquid level in the suction vessel.
3. Change the pump.
4. Reduce motor RPM if possible.
5. Increase the diameter of the eye of the impeller.
6. Use an impeller inducer.
7. Use two lower capacity pumps in parallel

### **18. What are the advantages of fluid power? (Nov/Dec 2009)**

- High horsepower-to-weight ratio you could probably hold a 5-hp hydraulic motor in the palm of your hand, but a 5-hp electric motor might weight 40 lb or more.
- Safety in hazardous environments because they are inherently spark-free and can tolerate high temperatures.
- Force or torque can be held constant — this is unique to fluid power transmission
- High torque at low speed — unlike electric motors, pneumatic and hydraulic motors can produce high torque while operating at low rotational speeds. Some fluid power motors can even maintain torque at zero speed without overheating
- Pressurized fluids can be transmitted over long distances and through complex machine configurations with only a small loss in power
- Multi-functional control — a single hydraulic pump or air compressor can provide power to many cylinders, motors, or other actuators
- Elimination of complicated mechanical trains of gears, chains, belts, cams, and linkages
- Motion can be almost instantly reversed

**19. State Pascal's law (Nov/Dec 2009)**

Pascal's law states that the pressure of a gas or liquid exerts force equally in all directions against the walls of its container. The force is measured in terms of force per unit area (pounds per square inch—psi). This law is for liquids and gases at rest and neglects the weight of the gas or liquid. It should be noted that the field of fluid power is divided into two parts, pneumatics and hydraulics. These two have many characteristics in common. The difference is that hydraulic systems use liquids and pneumatic systems use gases, usually air. Liquids are only slightly compressible and in hydraulic systems this property can often be neglected. Gases, however, are very

**20. Give any two differences between hydraulic and pneumatic power (April/May2010)**

1. The working fluid in Pneumatic system is air and in hydraulic it is oil
2. Pneumatic will be used for low pressure requirements, whereas hydraulic is used in case of more pressure requirements.
3. Hydraulic system produces pressure exponentially
4. Application for Pneumatic system is, they are used for automatic closing and opening of bus doors.
5. Application for hydraulic system: they are used in high capacity presses.

**21. Give the expression used to determine friction factor for laminar flow through pipes (April/May2010)**

For practical purposes, if the Reynolds number is less than 2000, the flow is laminar. The accepted transition Reynolds number for flow in a circular pipe is  $Re_{d,crit} = 2300$ . For laminar flow, the head loss is proportional to velocity rather than velocity squared, thus the friction factor is inversely proportional to velocity.

The Darcy friction factor for laminar (slow) flows is a consequence of Poiseuille's law that and it is given by following equations:

Circular Pipes:  $f = \frac{64}{Re}$

Non - Circular Pipes:  $f = \frac{k}{Re}$ ,  $48 \leq k \leq 96$

Geometry Factor k	
Square	56.91
2:1 Rectangle	62.19
5:1 Rectangle	76.28
Parallel Plates	96.00

22. Sketch the graphical symbol of variable displacement reversible pump and telescopic cylinder (April/May2010)

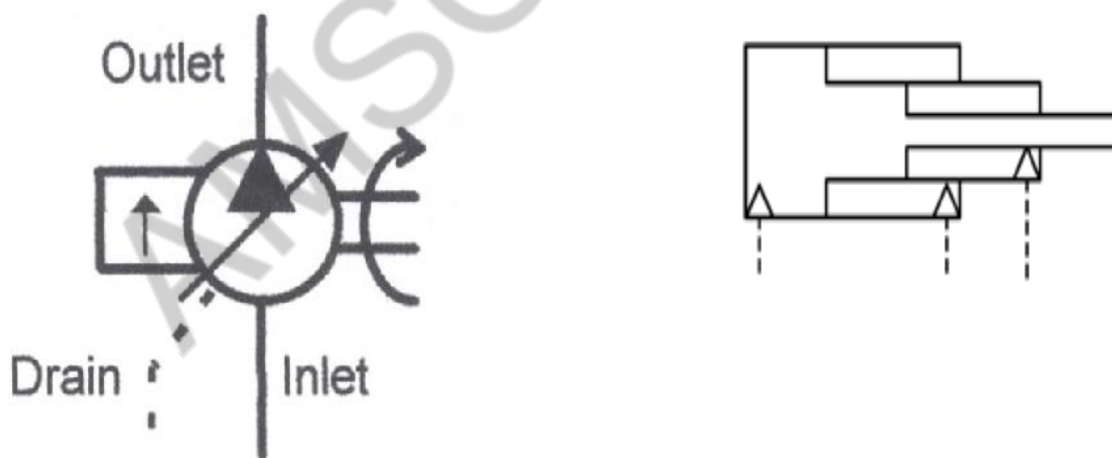

Fig: Variable displacement reversible pump and telescopic cylinder



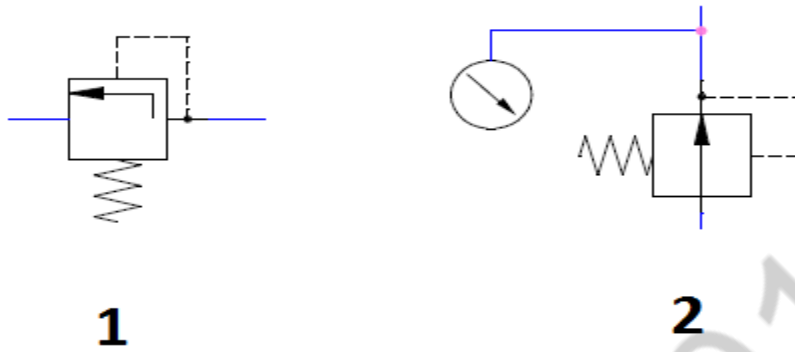

Fig: Symbol of pneumatic regulator

AMSCCE-1101

## UNIT-I

### PART-B

#### 1. List out the advantages and disadvantages of hydraulic system (April/May2008)

*Table 1.4. Advantages of hydraulic power systems*

1. Hydraulic power is easy to generate, transmit, store, regulate and control, maintain and transform.
2. Hydraulic power systems can generate and transmit large tonnes and forces to any part of a machine. It is also possible to amplify ( <i>i.e.</i> , multiply) the force and power.
3. The hydraulic power systems provide reversible, infinitely variable speed and load control.
4. They can achieve accurate feed back control of load, position, <i>etc.</i>
5. They offer cushioning for shock loads. Hence the noise and vibration produced are minimal.
6. The wear of the system is reduced due to the self-lubrication action of the transmission medium.
7. They are mechanically safe, compact and can be easily controlled.
8. The power-to-weight ratio of a hydraulic power system is comparatively higher than that for electrical and mechanical power systems.
9. The hydraulic output can be linear and rotational. Use of flexible connection hydraulic system permits generation of complex motion, which is impractical with the kinematic linkages such as gear, belts, cams, <i>etc.</i>
10. The hydraulic power systems offer safe operation for both operator and machine.
11. Hydraulic elements can be located easily at any place and can be controlled reversely.
12. This system is a better over-load safe power system. This can be easily achieved by using a pressure relief valve.

## 2. Disadvantages of Hydraulic Power Systems

Table 1.5 presents some of the major disadvantages of hydraulic systems.

*Table 1.5. Drawbacks of hydraulic power systems*

1. Hydraulic fluid leakage poses many problems to the operations as well as operators.
2. Flammable hydraulic fluids may pose fire hazards thus limiting the upper level of working temperature.
3. Hydraulic elements require special treatments to protect them against rust, corrosion, dirt, etc. Otherwise the contaminated elements may impair the system operation.
4. Hydraulic fluids may pose problems if it disintegrates due to ageing and chemical deterioration.

2. What is the function of fluid power system in any fluid power system? (April/May2008)

### 1.7.3.2. Working of the Total Hydraulic System

The total hydraulic system for the task of moving a weight ( $W$ ) by a distance ( $D$ ) is shown in Fig.1.1(b). The parts enclosed in the dotted-lined box are common to an area of the plant, which may have many linear and rotary hydraulic actuators. In this case, we use only one linear hydraulic actuator.

AC induction motor ( $M$ ) drives the hydraulic pump ( $P$ ), so that the fluid is pumped from the tank at the required pressure. The fluid circulated into the system should be clean to reduce the wear of the pump and cylinder; hence a filter is used immediate to the storage tank. Since the pump delivers constant volume of fluid for each revolution of the shaft, the fluid pressure rises indefinitely, until a pipe or pump itself fails. To avoid this, some kind of pressure regulator is used to spill out the excess fluid back to the tank.

Cylinder movement is controlled by a 3-position changeover control valve. One side of the valve is connected to a pressurized fluid line and the fluid retrieval line; and other side of the valve is connected to port A and port B of the cylinder. Since the hydraulic circuit is a closed one, the liquid transferred from the storage tank to one side of the piston, and the fluid at the other side of the piston is retrieved back to the tank.

**3 What are the required properties of good hydraulic fluid (April/May2008)**

**(Nov/Dec 2009)**

1. Stable viscosity characteristics.
2. Good lubricity.
3. Compatibility with system materials.
4. Stable physical and chemical properties.
5. Good heat dissipation capability.
6. High bulk modulus and degree of incompressibility.
7. Adequate low-temperature properties (such as cloud point, pour point and freezing point).
8. Good flammability characteristics (such as flash and fire points).
9. Low volatility.
10. Good demulsibility.
11. Better fire resistance.
12. Lower foaming<sup>†</sup> tendency.
13. Nontoxicity.
14. Good oxidation stability.
15. Better rust-and corrosion-preventive qualities.
16. Low density and specific gravity.
17. Low coefficient of expansion.
18. Simple and easy handling.
19. Ready availability.
20. Inexpensive.

#### 4. Short notes on the following (Nov/Dec 2011)

##### i) Laminar and turbulent flow

As we know, the hydraulic system is concerned with the flow of a liquid through a pipe. Two important types of flow are :

1. Laminar flow, and 2. Turbulent flow.<sup>†</sup>

##### 1. Laminar Flow

- ✓ A laminar flow is one in which paths taken by the individual particles do not cross one another and move along well defined paths, as shown in Fig.4.11.
- ✓ The laminar flow is characterized by the fluid flowing in smooth layers of laminae.
- ✓ This type of flow is also known as *streamline* or *viscous flow*, because the particles of fluid moving in an orderly manner and retaining the same relative positions in successive cross-sections.

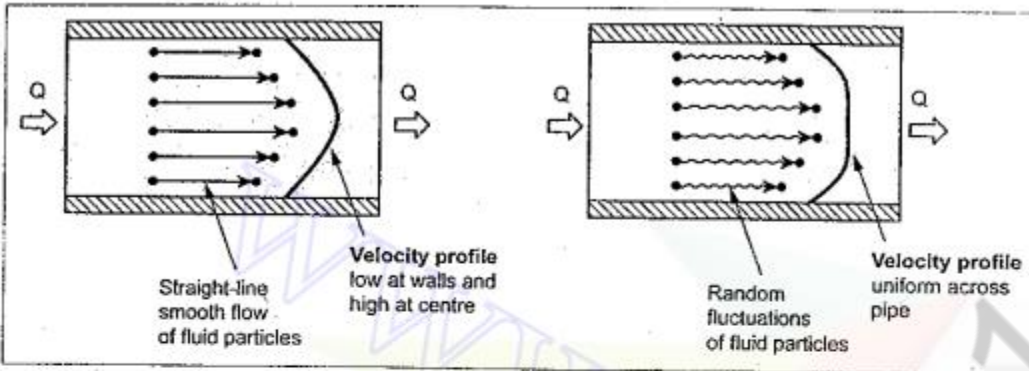

Fig. 4.11. Laminar flow

Fig. 4.12. Turbulent flow

- ✓ **Examples :** (i) Flow of oil in measuring instruments.
- (ii) Flow of blood in veins and arteries.
- (iii) Rise of water in plants through their roots.

## 6.2. Turbulent Flow

- ✓ A turbulent flow is that flow in which fluid particles move in a zig-zag way, as shown in Fig.4.12.
- ✓ The turbulent flow is characterized by continuous small fluctuations in the magnitude and direction of the velocity of the fluid particles.
- ✓ **Causes :** The turbulence in the fluid may cause :
  - (i) More resistance to flow,
  - (ii) Greater energy loss, and
  - (iii) Increased fluid temperature due to greater energy loss.
- ✓ **Examples :** High velocity flow in a pipe of large size. Nearly all fluid flow problems encountered in engineering practice have a turbulent character.

## REYNOLD'S NUMBER

- ✓ Reynolds from his experiments found that the nature of flow in a closed pipe depends upon the following factors :
  - (i) Diameter of the pipe (D),
  - (ii) Density of the liquid ( $\rho$ ),
  - (iii) Viscosity of the liquid ( $\mu$ ), and
  - (iv) Velocity of flow (V).
- ✓ By combining the above variables, Reynolds determined a non-dimensional quantity equal to  $\frac{\rho V D}{\mu}$  which is known as **Reynolds number (Re)**.

$$\therefore \text{Reynolds number, } Re = \frac{\rho V D}{\mu} = \frac{V D}{\nu} \quad [\because \nu = \frac{\mu}{\rho}] \quad \dots (4.16)$$

✓ Laminar and turbulent flows are characterised on the basis of Reynolds number.

- |  |
|--|
| 1. If Reynolds number ( $Re$ ) $< 2000$ , then the flow in pipes is <i>laminar</i> .     |
| 2. If Reynolds number ( $Re$ ) $> 4000$ , then the flow in pipes is <i>turbulent</i> .   |
| 3. If Reynolds number is between 2000 and 4000, then the flow in pipes is unpredictable. |

✓ Since turbulent flow results in greater losses, therefore hydraulic systems should be designed to operate in the laminar flow region.

✓ The turbulent flow can be converted into laminar flow by either reducing the velocity of liquid or by increasing the pipe diameter.

## ii) Energy losses in valves and fittings

### LOSSES IN VALVES AND FITTINGS

- The loss of head in the various valves and fittings (such as tees, elbows, and bends) is given by the relation :

$$H_L = K \left( \frac{V^2}{2g} \right) \quad \dots (4.27)$$

where  $K$  = Constant of proportionality called 'the *K-factor*'.

- The value of  $K$ -factor depends on the type of valves and pipe fittings. Table 4.2 gives typical  $K$ -factor values for several common types of valves and fittings.
- If the loss of head  $H_L$  is known, it can be expressed into equivalent pressure drop by using the relation,

$$\Delta P = H_L \times w_{oil} \quad \dots (4.28)$$

where  $w_{oil}$  = Weight density of oil flowing through valves and fittings.

Table 4.2. *K*-factors of common valves and fittings

Valve or Fitting	K-Factor
Globe valve: Wide open	10.0
$\frac{1}{2}$ open	12.5
Gate valve: Wide open	0.19
$\frac{3}{4}$ open	0.90
$\frac{1}{2}$ open	4.5
$\frac{1}{4}$ open	24.0
Return bend	2.2
Standard tee	1.8
Standard elbow	0.9
45° Elbow	0.42
90° Elbow	0.75



### iii) Darcy equations

#### 4.14. DARCY'S EQUATION

- ✓ The major energy losses i.e., the energy losses due to friction in the pipe can be calculated by using Darcy's equation.
- ✓ The Darcy's equation for the loss of head due to friction in pipes is as follows :

$$H_L = f \left( \frac{L}{D} \right) \left( \frac{V^2}{2g} \right) \quad \dots (4.23)$$

where  $H_L$  = Loss of head due to friction in pipe in m,

$f$  = Friction factor,

$L$  = Length of pipe in m,

$D$  = Inside diameter of the pipe in m,

$V$  = Average velocity of liquid in m/s, and

$g$  = Acceleration due to gravity in  $m/s^2$ .

- ✓ The Darcy's equation holds good for both laminar and turbulent flow provided a proper value of friction factor ' $f$ ' is evaluated.

### 5. Discuss any four hydraulic principles used in hydraulic system (Nov/Dec 2009)

A simple hydraulic system consists of hydraulic fluid, pistons or rams, cylinders, accumulator or oil reservoir, a complete working mechanism, and safety devices. These systems are capable of remotely controlling a wide variety of equipment by transmitting force, carried by the hydraulic fluid, in a confined medium. Modern developments in hydraulics have involved many fields in engineering and transportation. These systems transfer high forces rapidly and accurately even in small pipes of light weight, small size, any shape, and over a long distance. These systems play a vital role from small car's steering to supersonic aircraft's maneuvering devices. More powerful and accurate systems are also used in maneuvering huge ships.

- Fluid pressure creates force on a piston creates movement against a spring.
- Pressure drop across an orifice creates flow proportional to the orifice size.
- Load pressure changes, affect the control pressure.
- Leakage results from small clearances between the spools and bores.
- Dynamic seals reduce leakage but cause hysteresis.
- Restricting volume changes is used to control timings.

## 6. Discuss any application of fluid power (Nov/Dec 2009) (Nov/Dec2013)

The applications of hydraulic and pneumatic power systems cannot be simply listed/counted, because new uses of them are being found and adopted every day in all fields. However few of the applications of fluid power are summarised in Table 1.8.

*Table 1.8. Applications of fluid power*

Sl.No.	Industry/Field	Applications
1.	Manufacturing industry	Hydraulic presses, pneumatic hand tools, hydraulic and pneumatic fixtures, automatic and semi-automatic operating machines such as machines with hydraulic feed, pneumatic drive, automatic indexing machine, hydraulic-driven die-casting machine, hydraulic feed machines, automatic lathe with air-operated equipment, hydraulically operated shaving machines, cutting machines, drilling machines, etc.
2.	Automobile industry	Welding equipment using hydraulic controls, hydraulic brakes, automotive transmissions, power steering, power brakes, air conditioning, lubrication, water coolant, and gasoline pumping systems.
3.	Agriculture industry	Hydraulic and pneumatic driven elevator conveyors for use in harvesting of grains; fluid power driven farm equipments.
4.	Naval industry	Fluid power used for cargo handling, winches, propeller pitch control, submarine control systems, operation of shipboard aircraft elevators, and drive systems for radar and sonar.
5.	Aviation and Aerospace industry	Hydraulic-actuated landing gears, cargo doors, gun drives, and flight control devices such as rudders, ailerons, and elevators for aircraft; fluid powered missile launching systems.
6.	Mechatronics field	Fluid logic components, servo-controlled pneumatic actuators in robotics and tactile sensing; Fluid power used for operating various mechatronic elements such as spindle drives, feed drives, automatic tool clamping and work clamping, tool magazines and automatic tool chargers, etc.

**7. Explain how Bernoulli's equation can be used to determine the pressure drop between two stations in a hydraulic system (Nov/Dec 2009)**

✓ Bernoulli equation states as follows :

*"In an ideal, incompressible fluid when the flow is steady and continuous, the sum of potential energy, kinetic energy and pressure energy is constant across all cross sections of the pipe."*

✓ For the incompressible fluid flowing through a non-uniform pipe shown in Fig.4.15, the Bernoulli's equation can be written as,

$$z_1 + \frac{V_1^2}{2g} + \frac{P_1}{w} = z_2 + \frac{V_2^2}{2g} + \frac{P_2}{w} \quad \dots (4.21)$$

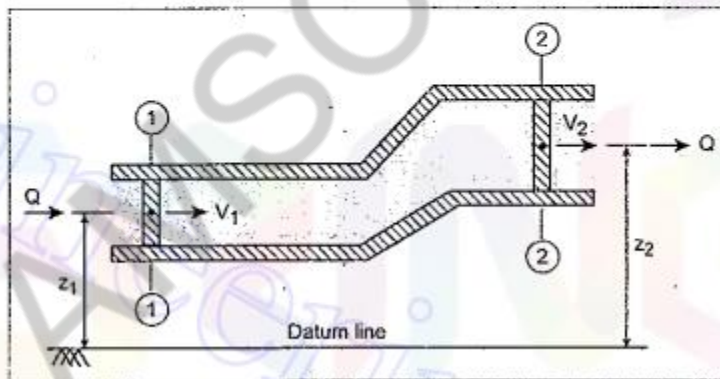

**Fig. 4.15. Flow through pipe**

8. What types of fluids are available for hydraulic system? (Nov/dec2011) (Nov/Dec2013)

○ There are two different types fluid systems. They are :

- 1. Fluid transport systems, and
- 2. Fluid power systems.

○ The differences between them are presented in Table 1.1.

*Table 1.1. Fluid transport systems Vs Fluid power systems*

- |  |
|--|
| <p>1. <b>Fluid Transport Systems</b> : ✓ The objective of the fluid transport systems is to transport/deliver fluids from one place to another place to achieve some useful purpose.</p> <p>✓ <b>Examples</b> : Some of the examples of fluid transport systems include :</p> <ol style="list-style-type: none"><li>(i) Transport of water from water reservoirs (such as wells/ rivers) to houses/ industries using pipe lines; and</li><li>(ii) Transport of petroleum oil/ gas from one country to another through oil/ gas pipe lines.</li></ol> |
| <p>2. <b>Fluid Power Systems</b> : ✓ The fluid power systems are primarily designed to perform work. That is, these systems use pressurized fluids to produce some useful mechanical movements to accomplish the desired work.</p>   |

*Table 1.2. Methods of transmitting power*

- |  |
|--|
| <p>1. <b>Electrical Power Transmission</b> : ✓ <b>Concept</b> : Electrical power is transmitted by imposing an electromagnetic field on a conductor.</p> <p>✓ <b>Suitability</b> : They are suitable for power transmission over long distances.</p> <p>✓ <b>Disadvantages</b> : The limitations of electric power transmission include magnetic saturation (which may limit the torque developed by an electric motor); material limitations (which may affect the speed); and heat dissipation problem.</p>  |
| <p>2. <b>Mechanical Power Transmission</b> : ✓ <b>Concept</b> : Mechanical power is transmitted by employing a variety of kinematic mechanisms such as belts, chains, pulleys, sprockets, gear trains, bar linkages, and cams.</p> <p>✓ <b>Suitability</b> : They are suitable for the transmission of motion and force over relatively short distances.</p> <p>✓ <b>Disadvantages</b> : The disadvantages of mechanical power transmission include lubrication problems, limited speed and torque control capabilities, uneven force distribution, and relatively large space requirements.</p> |

### 3. Fluid Power Transmission :

(a) *Hydraulic Power Transmission* : ✓ *Concept* : Hydraulic power is transmitted by the pressure and flow of liquids. The most common liquids used are petroleum oils.

✓ *Suitability* : They are suitable for power transmission over intermediate distances. That is, they can be employed over greater distances than mechanical types but not as far as electrical systems.

✓ *Advantages* : Hydraulic systems are mechanically stiff, and can be designed to give fast operation and move very heavy loads.

✓ *Disadvantages* : The disadvantages of hydraulic system include hydraulic fluid leakage; impairment of system operation by contamination; and fire hazards with flammable hydraulic fluids.

(b) *Pneumatic Power Transmission* : ✓ *Concept* : Pneumatic power is transmitted by the pressure and flow of compressed gases. The most commonly used gas is air.

✓ *Suitability* : They are suitable for power transmission over intermediate distances.

✓ *Advantages* : Pneumatic systems use simple equipment, have small transmission lines, and do not present a fire hazard.

✓ *Disadvantages* : The disadvantages of pneumatic system include a high fluid compressibility and a small power-to-size ratio of components.

**9. What are the basic components that are required for a hydraulic system?  
Explain their functions (Nov/dec2011)**

**1.7. HYDRAULIC POWER SYSTEM**

As we know, the hydraulic system uses the pressurized hydraulic liquid as the fluid medium. Also *hydraulic system is always a closed loop system.*

**1.7.1. Arrangement**

The general arrangement of a basic hydraulic system is shown in Fig.1.1.

**1.7.2. Basic Components of a Hydraulic System**

A hydraulic system consists of six basic components, as shown in Fig.1.1(b). The basic components and their functions are presented in Table 1.9.

*Table 1.9. Basic components<sup>t</sup> of a hydraulic system*

1. <i>Reservoir (or tank)</i> : A reservoir is an oil supply tank. It is provided to hold the hydraulic liquid (usually oil).
2. <i>Pump</i> : A pump is used to force the liquid into the system.
3. <i>Prime mover</i> : A prime mover, usually an electric motor, is used to drive the pump.
4. <i>Valves</i> : Valves are fitted in the system to control liquid direction, pressure, and flow rate.
5. <i>Actuator</i> : An actuator is provided to convert the liquid energy into mechanical force or torque to do useful work. The actuator is the actual working element of the system. The actuators can be either cylinders (to provide linear motion) or hydro motors (to provide rotary motion).
6. <i>Fluid-transfer piping</i> : The hydraulic piping is provided to carry the liquid from one place to another.

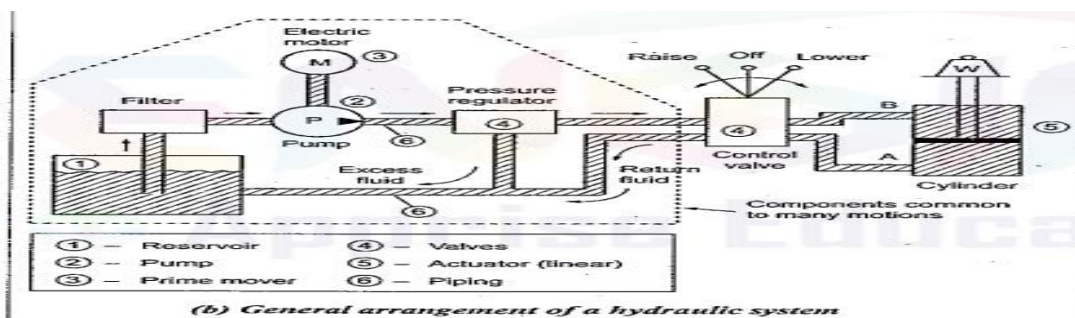

## 10. Write notes on (May/June 2013)

### i. Neutralization number

#### 2.22. NEUTRALIZATION NUMBER

- ✓ The term 'Neutralization number' is used to express an acidity or alkalinity of lubricating liquids and hydraulic fluids.
- ✓ **Definition:** The neutralization number is defined as the number of milligrams of potassium hydroxide required to neutralize all the acids present in one gram of the sample.

### ii. Frictional losses in laminar and turbulent flow

#### 4.14.1. Frictional Losses in Laminar Flow

For laminar flow, the friction factor ' $f$ ' is function of Reynolds number only and is given by,

$$f = \frac{64}{Re} \quad \dots (4.24)$$

Substituting equation (4.24) into equation (4.23), we get

$$H_L = \frac{64}{Re} \left( \frac{L}{D} \right) \left( \frac{V^2}{2g} \right) \quad \dots (4.25)$$

The above equation is known as the **Hagen-Poiseuille equation**, which is valid only for laminar flow.

#### 4.14.2. Frictional Losses in Turbulent Flow

- ✓ Unlike for laminar flow, the friction factor ' $f$ ' for turbulent flow is a function of Reynolds number as well as the relative roughness of the pipe.
- ✓ The **relative roughness** is defined as the pipe inside surface roughness ( $\epsilon$ ) divided by the inside diameter of the pipe ( $D$ ).

$$\therefore \text{Relative roughness} = \frac{\epsilon}{D} \quad \dots (4.26)$$

- ✓ In equation (4.26), the ' $\epsilon$ ' is called the **absolute roughness**. Table 4.1 gives typical values of absolute roughness for various types of pipes. For a given pipe, the appropriate ' $\epsilon$ ' value may be selected using the Table 4.1.

*Table 4.1. Typical values of absolute roughness*

Types of pipe	Absolute roughness $\epsilon$ (mm)
Glass or plastic	Smooth
Drawn tubing	0.0015
Commercial steel or wrought iron	0.046
Asphalted cast iron	0.12
Galvanized iron	0.15
Cast iron	0.26
Riveted steel	1.8

- ✓ Once we calculate the relative roughness ( $\epsilon/D$ ) and Reynolds number, we can determine the friction factor for use in Darcy's equation by using the Moody diagram. The Moody diagram is presented in Fig.4.16. The Moody diagram contains many curves. The curves indicate the value of friction factor as a function of Reynolds number and relative roughness.

AMSCSE -



**11. How will you measure the pump performance? Explain each with suitable example (April/May2005) (Nov/Dec2005)**

**16. PUMP PERFORMANCE**

The performance characteristics of a pump can be represented in terms of overall efficiency. Overall efficiency, in turn, has two components: 'Volumetric efficiency' and mechanical efficiency'. These three efficiencies are presented below.

**16.1. Volumetric Efficiency**

✓ **Definition :** It is the ratio between the actual flow rate produced by the pump and the theoretical flow rate that the pump should produce.

✓ **Formula :**

Volumetric efficiency =  $\frac{\text{Actual flow rate produced by the pump}}{\text{Theoretical flow rate that the pump should produce}} \times 100$

$$\eta_{vol} = \frac{Q_A}{Q_T} \times 100 \quad \dots (5.10)$$

✓ **Significance :** The volumetric efficiency indicates the amount of leakage within the pump. The lower the internal slip losses, the higher the volumetric efficiency. For zero slip, the volumetric efficiency is 100%.

**5.16.2. Mechanical Efficiency**

✓ **Definition :** It is the ratio between the theoretical power required to operate the pump and the actual power delivered to the pump.

✓ **Formula :**

Mechanical efficiency =  $\frac{\text{Theoretical power required to operate the pump}}{\text{Actual power delivered to pump}} \times 100 \quad \dots (5.11)$

or 
$$\eta_{mech} = \left( \frac{P \times Q_T}{T_A \times \omega} \right) \times 100 \quad \dots (5.12)$$

where

P = Pump discharge pressure in N/m<sup>2</sup>,

Q<sub>T</sub> = Theoretical flow rate of the pump in m<sup>3</sup>/s,

T<sub>A</sub> = Actual torque delivered to pump in N-m,

ω = Angular speed of the pump in rad/s =  $\frac{2\pi N}{60}$ , and

N = Speed of the pump in r.p.m.

Mechanical efficiency can also be calculated in terms of torques as follows :

$$\eta_{mech} = \frac{\text{Theoretical torque required to operate pump}}{\text{Actual torque delivered to pump}} \times 100 \quad \dots (5.13)$$

$$\eta_{mech} = \frac{T_T}{T_A} \times 100$$

Here 
$$T_T \text{ (N.m)} = \frac{V_D \text{ (m}^3\text{)} \times P \text{ (Pa)}}{2 \pi} \quad \dots (5.14)$$

and 
$$T_A = \frac{\text{Actual power delivered to pump (watts)}}{\left(\frac{2\pi N}{60}\right)} \quad \dots (5.15)$$

- ✓ **Significance :** The mechanical efficiency indicates the amount of energy lost due to friction in bearings and other mating parts, and energy lost due to fluid turbulence. In other words, *the mechanical efficiency indicates the amount of energy losses that occur due to reasons other than leakages.*
- ✓ Since the amount of power required to overcome friction rises with increased liquid viscosity, mechanical efficiency decreases as liquid viscosity decreases.
- ✓ Power losses in timing gears, bearings and seals reduce mechanical efficiency.

### 5.16.3. Overall Efficiency

- ✓ **Definition :** It is the ratio between the actual power delivered by pump and the actual power delivered to pump.

- ✓ **Formula :**

$$\text{Overall efficiency} = \frac{\text{Actual power delivered by pump}}{\text{Actual power delivered to pump}} \times 100 \quad \dots (5.16)$$

Mathematically, the overall efficiency can also be written as

$$\eta_0 = \text{Volumetric efficiency} \times \text{Mechanical efficiency}$$

or 
$$\eta_0 = \eta_{vol} \times \eta_{mech} \quad \dots (5.17)$$

Substituting equations (5.10), (5.12), and (5.17), we get

$$\eta_0 = \left( \frac{P \cdot Q_A}{T_A \cdot \omega} \right) \times 100 \quad \dots (5.18)$$

- ✓ **Significance :** *The overall efficiency indicates the amount of energy losses by all means.*

ii)

A pump has a displacement volume of 98.4 cm<sup>3</sup>. It delivers 0.00152 m<sup>3</sup>/s of oil at 1000 rpm and 70 bars. If the prime mover input torque is 124.3 N-m (1) What is the overall efficiency of the pump? (2) What is the theoretical torque required to operate the pump? (8)

**Given Data :**  $V_D = 98.4 \text{ cm}^3 = 98.4 \times 10^{-6} \text{ m}^3$ ;  $Q_A = 0.00152 \text{ m}^3/\text{s}$ ;  $N = 1000 \text{ rpm}$ ;  $P = 70 \text{ bar} = 70 \times 10^5 \text{ N/m}^2$ ;  $T_A = 124.3 \text{ N-m}$ .

© **Solution :**  $\omega = 2\pi N/60 = 2\pi (1000)/60 = 104.72 \text{ rad/s}$ .

(1) To find overall efficiency of the pump ( $\eta_o$ ) :

We know that,

$$\eta_o = \frac{P \times Q_A}{T_A \cdot \omega} \times 100$$

$$= \frac{(70 \times 10^5) (0.00152)}{124.3 \times 104.72} \times 100 = 81.74\% \text{ Ans. } \curvearrowright$$

(2) To find the theoretical torque required to operate the pump ( $T_T$ ) :

We know that,

$$T_T = \frac{V_D \times P}{2\pi}$$

$$= \frac{(98.4 \times 10^{-6}) (70 \times 10^5)}{2\pi} = 109.62 \text{ N-m Ans. } \curvearrowright$$

12. How do you classify pumps? Explain with suitable sketch the working of vane pump (Nov/Dec2005)

With reference to the fluid power applications, pumps can be broadly classified into: (i) Positive displacement pumps, and (ii) Non-positive displacement pumps: They are further classified into many types, as shown in Fig.5.2.

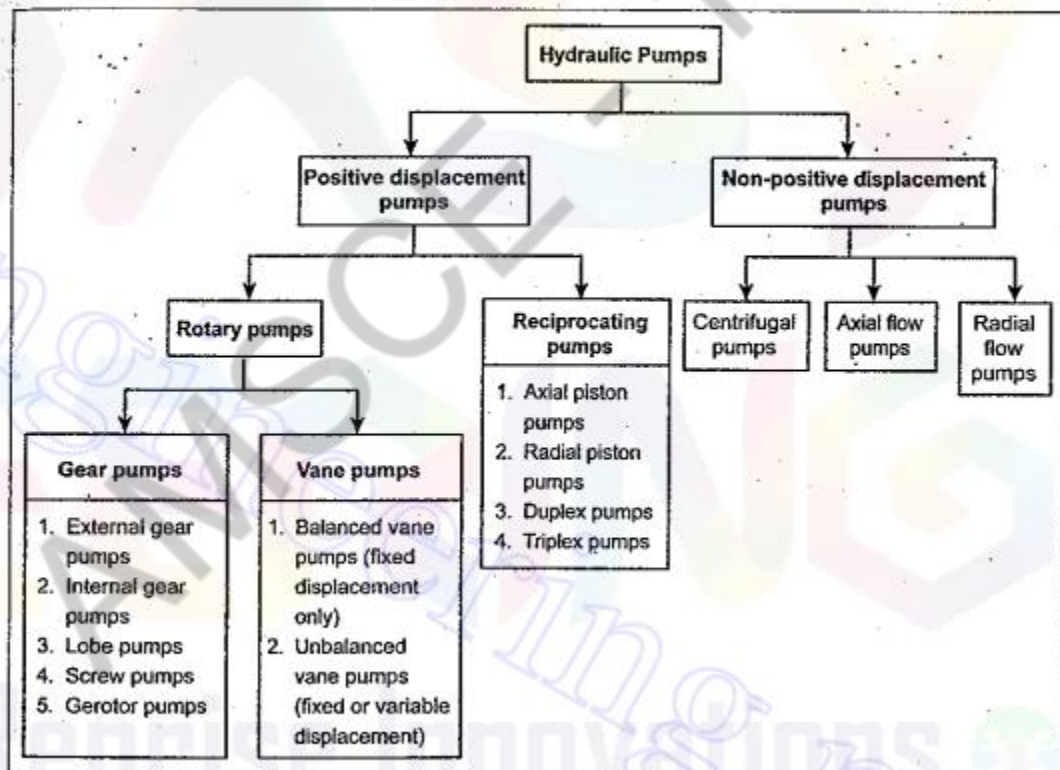

Fig. 5.2. Classification scheme of pumps

### 5.10.1. Introduction

The major problem in gear pumps is that the significant amount of leakage occurs between the small gaps of teeth, and also between teeth and pump housing. The vane pumps reduce this leakage by using spring-or hydraulic-loaded vanes.

### 5.10.2. Types of Vane Pumps

The two important types of vane pumps are :

1. Unbalanced vane pumps, and
  - (a) Fixed-displacement unbalanced pumps, and
  - (b) Variable-displacement unbalanced pumps.
2. Balanced vane pumps.

---

## 5.11. UNBALANCED VANE PUMP

---

### 5.11.1. Construction and Operation

Fig.5.9 illustrates a typical unbalanced sliding-vane pump.

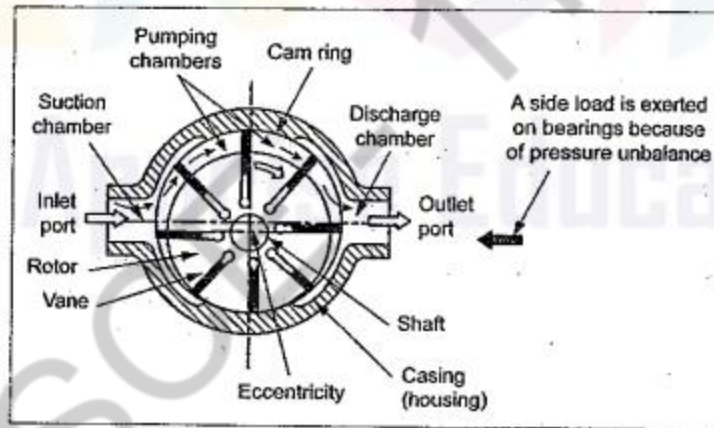

In this pump, the rotor is mounted off-center. At regular intervals around the curved surface of the rotor are rectangular vanes that are free to move in a radial slot. As the rotor revolves, the vanes are thrown outwards by centrifugal force to form a seal against the fixed casing. The eccentricity of the revolving rotor produces a partial vacuum at the suction side of the pump, causing an inflow of liquid. This is carried to other side of the pump in the space between the rotor and the fixed casing.

Generally, pumping rates of these rotary pumps are varied by changing the speed of the rotor. However in unbalanced vane pumps, the pumping rate can also be varied by changing the degree of eccentricity of the rotor, since this determines the amount of liquid carried through per cycle.

## 5.12. BALANCED VANE PUMP

### 5.12.1. Construction and Operation-

Unlike in unbalanced vane pump, the balanced vane pump has two intake and two outlet ports which are diametrically opposite to each other. Also a balanced vane pump has an elliptical housing instead of a circular cam ring. This configuration creates two diametrically-opposed volumes. The two high-pressure zones balance the forces on the rotor shaft and hence a complete hydraulic balance is achieved.

Fig.5.10 illustrates the operation of a balanced vane pump. Except the above said differences, the construction and basic working principle are similar to the unbalanced vane pumps.

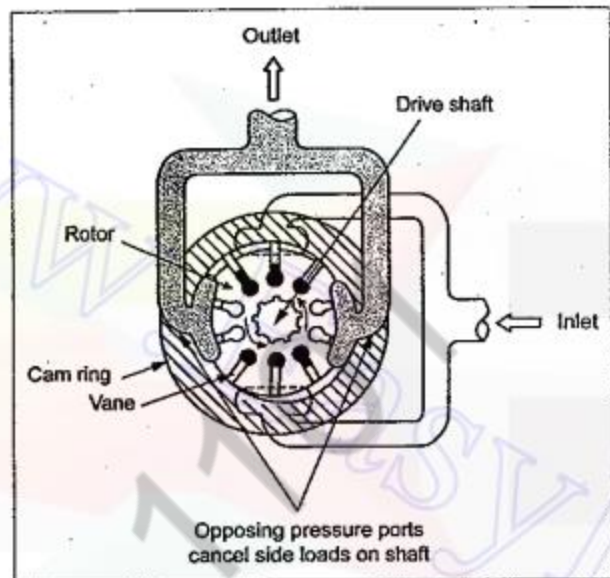

*Fig. 5.10. Balanced vane pump operation*

AMSC

13 .Explain the working principles of external gear pump and determine its performance measure (Nov/Dec2006)

## 5.5. EXTERNAL GEAR PUMPS

### 5.5.1. Construction

External gear pumps have two mating gears (driver and follower) that are turned in a closely fitted casing, as shown in Fig.5.3. Each gear is mounted on a shaft which is supported on bearings in the end covers. In these, the driver shaft is coupled to the prime mover (electric motor, gasoline engine, *etc.*). Two parts—inlet and delivery parts—are provided directly on the opposite sides of the mesh point of the gears. The larger and straight ports are preferred for better performance. The driving shaft is usually connected to the upper gear of the pump. The rotation of the driver gear causes the follower gear to turn.

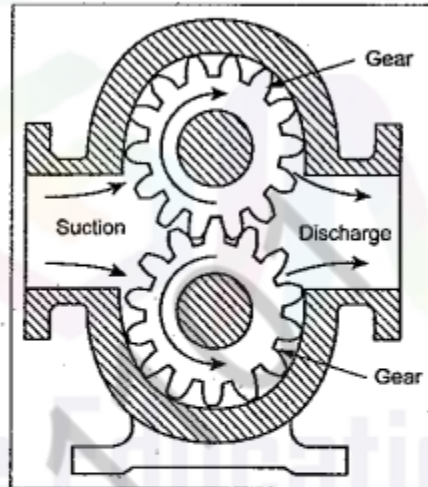

*Fig. 5.3. External gear pump*

### 5.5.2. Operation

The self-explanatory Fig.5.4 explains the operation of the external gear pump in steps.

When the pump starts rotating, the rotation of gears forces air out of the casing and into the discharge pipe [Fig.5.4(a)]. This removal of air from the pump casing produces a partial vacuum on the suction side of the pump. Fluid from an external reservoir is forced by the

atmospheric pressure into the pump inlet. Here the fluid is trapped between the teeth of the upper and lower gears and the pump casing [Fig.5.4(b)]. Continued rotation of the gears forces the fluid out of the pump discharge [Fig.5.4(c)].

A vacuum is formed in the cavity between the teeth as they un-mesh, causing more fluid to be drawn into the pump. Pressure rise in the pump is produced by the squeezing action on the fluid as it is expelled from between the meshing gear teeth and the casing.

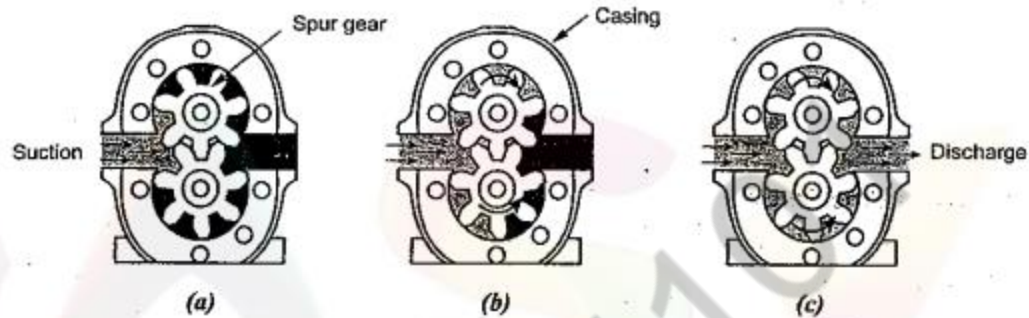

Fig. 5.4. Operation of external gear pumps : (a) Vacuum draws fluid into pump. (b) Teeth carry fluid through pump. (c) Fluid is discharged under pressure.

### 5.5.3. Analysis of Volumetric Displacement and Theoretical Flow Rate

The volumetric displacement and theoretical flow rate of a gear pump can be determined as follows :

- Let
- $D_i$  = Inside diameter of gear teeth in m,
  - $D_o$  = Outside diameter of gear teeth in m,
  - $L$  = Width of gear teeth in m,
  - $N$  = Speed of pump in rpm,
  - $V_D$  = Volumetric displacement of the pump in  $m^3/rev$ , and
  - $Q_T$  = Theoretical pump flow rate in  $m^3/sec$ .

If addendum and dedendum of a gear is known, then inside diameter of gear teeth can be calculated by

$$D_i = D_o - 2 (\text{Addendum} + \text{Dedendum})$$

The volumetric displacement, from the geometry of the gear teeth, is given by,

$$V_D = \frac{\pi}{4} (D_o^2 - D_i^2) L \quad \dots (5.1)$$

Then the theoretical flow rate can be calculated as

$$Q_T = \frac{V_D \times N}{60} \quad \dots (5.2)$$

From equation (5.2), it is evident that the pump flow rate depends on :

(i) Size of the gear, and (ii) Speed of the pump.

**Note** If the gear is specified by its module and number of teeth, then the theoretical discharge can be found by using the following empirical relation :

$$Q_T = 2\pi L m^2 N \left[ z + \left( 1 + \frac{\pi^2 \cos \alpha}{12} \right) \right] \text{ m}^3/\text{min} \quad \dots (5.3)$$

where  
L = Width of gear teeth in m,  
m = Module of gear in m,  
N = Pump speed in rpm, and  
z = Number of gear teeth.

### Volumetric efficiency

$$\therefore \text{Volumetric efficiency, } \eta_{vol} = \frac{Q_A}{Q_T} \times 100 \quad \dots (5.4)$$

where  $Q_A$  and  $Q_T$  are actual and theoretical flow rate of the pump respectively.

Since the internal leakage increases with the increase in discharge pressure, the volumetric efficiency will be lower for the high discharge pressure.

From equation (5.2), it is evident that the pump flow rate depends on :

(i) Size of the gear, and (ii) Speed of the pump.

**Note** If the gear is specified by its module and number of teeth, then the theoretical discharge can be found by using the following empirical relation :

$$Q_T = 2\pi L m^2 N \left[ z + \left( 1 + \frac{\pi^2 \cos \alpha}{12} \right) \right] \text{ m}^3/\text{min} \quad \dots (5.3)$$

where  
L = Width of gear teeth in m,  
m = Module of gear in m,  
N = Pump speed in rpm, and  
z = Number of gear teeth.

#### 5.5.4. Volumetric Efficiency

Obviously there will be a small radial clearance between the gear teeth and the casing so as to achieve the gears rotation. As a result, some of the fluid may leak inside the system without discharging at the outlet port. This internal leakage, also known as '*pump slippage*', results in lesser flow rate ( $Q_A$ ) than the theoretical flow rate ( $Q_T$ ). This is represented by the volumetric efficiency.

$$\therefore \text{Volumetric efficiency, } \eta_{vol} = \frac{Q_A}{Q_T} \times 100 \quad \dots (5.4)$$

where  $Q_A$  and  $Q_T$  are actual and theoretical flow rate of the pump respectively.

Since the internal leakage increases with the increase in discharge pressure, the volumetric efficiency will be lower for the high discharge pressure.



ii) Write short notes on variable displacement pump

**2. Variable Displacement Pumps :** In variable displacement pumps, the displacement can be varied by changing the physical relationships of various pump elements. This change in pump displacement produces a change in output of fluid flow even though pump speed remains constant.

- ✓ **Examples :** Some of the positive displacement pumps are gear, vane, piston, and screw pumps.

14. With a neat sketch explain the construction ,working , advantages , application and limitation of non pressure compensated reciprocating vane pump (Nov/Dec2006)  
(Refer Q.No.12)

Table 5.5. Advantages and disadvantages of vane pumps

Advantages	Disadvantages
<ul style="list-style-type: none"><li>✓ Vane pumps are self-priming, robust, and give constant delivery for a set rotor speed.</li><li>✓ They produce uniform discharge with negligible pulsations.</li><li>✓ Their vanes are self-compensating for wear and also vanes can be easily replaced.</li><li>✓ These pumps do not require check valves.</li><li>✓ They can pump in either direction.</li><li>✓ They require little space.</li><li>✓ They are light in weight.</li><li>✓ They can handle liquids containing vapours and gases.</li><li>✓ Volumetric and overall efficiencies are relatively high.</li><li>✓ Only small changes in capacity occur with variations in viscosity and discharge pressure.</li></ul>	<ul style="list-style-type: none"><li>✓ Vane pumps cannot be operated against a closed discharge without damage to the pump. Hence relief valves are required.</li><li>✓ They cannot handle abrasive liquids.</li><li>✓ They require seals.</li><li>✓ Foreign bodies can damage the pump.</li></ul>

15. Explain the working and construction of gear pump (Nov/Dec2007) Refer Q.No:13

## 5.6. INTERNAL GEAR PUMP

### 5.6.1. Introduction

The operation of internal gear pumps is very much similar to external gear pumps, but they are very efficient and produce less noise. The gears rotate in the same direction, with the inner gear rotating at a higher speed. Generally the internal gear pumps are used for low output applications at pressures below 70 bar. This pump is also known as *crescent seal pumps*.

### 5.6.2. Construction

Internal gear pump consists of an internal spur gear, an outside ring gear, a crescent shaped spacer, and an external housing, as shown in Fig.5.5. The internal spur gear drives the outside ring gear which is set off-center (*i.e.*, both gears are eccentric to each other). The inner and outer gears are separated by a crescent shaped spacer, which is a stationary part of the housing around which oil is carried. The inlet and outlet ports are located in the end plates between where the gear teeth mesh and un-mesh at the two ends of the crescent shaped spacer.

### 5.6.3. Operation

The operation of the internal gear pumps is similar to external gear pumps. Oil is transferred from the inlet to the outlet port. The internal gear drives the external gear and affects a fluid tight seal at the place where the teeth start meshing. Rotation causes the teeth to un-mesh near the inlet port, the cavity volume increases and the suction occurs. The oil is trapped between the internal and external gear teeth on both sides of the crescent shaped spacer and is carried from the inlet to the outlet cavity of the pump, as shown in Fig.5.5. Meshing of the gear teeth reduces the volume in the high pressure cavity near the outlet port and exits from the outlet port.

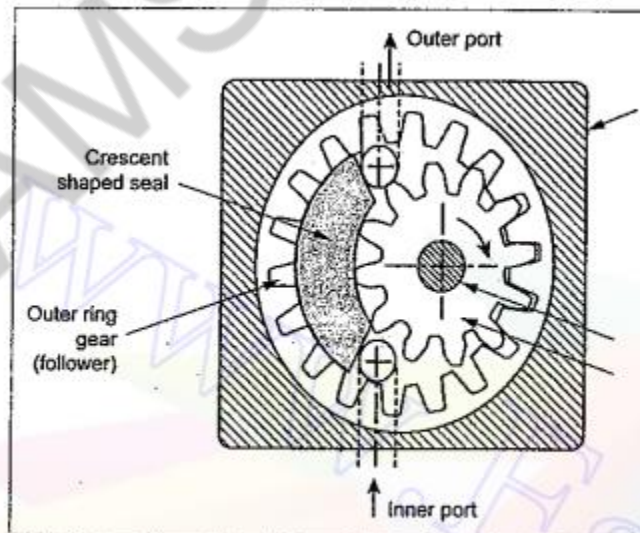

Fig. 5.5. Operation of an internal gear pump

## UNIT II

### HYDRAULIC ACTUATORS AND CONTROL COMPONENTS

#### PART-A

##### **1. What is a telescopic Cylinder? Nov/Dec2011**

Telescopic cylinders are a special design of a hydraulic cylinder or pneumatic cylinder as well as pulley system which provide an exceptionally long output travel from a very compact retracted length. Some pneumatic telescoping units are manufactured with retracted lengths of under 15% of overall extended unit length.

##### **2. What is the function of unloading valve and sequence valve? Nov/Dec 2012**

a) The unloading valve is useful to control the amount of flow at any given time in systems having more than one fixed delivery pump.

b) When the operation of two cylinders is required to be performed in Sequence, the sequence valve is used

##### **3. Differentiate double rod and tandem cylinder May/June2013**

Tandem cylinders consist of two cylinders in one housing. They have four ports and the back cylinder is single-rod end while the front cylinder is double-rod end. Because the front cylinder is double-rod end, it has equal areas and volumes on both sides of the piston

##### **4. Mention advantages of air motor over electric motor. May/ June 2013**

The greatest advantage of an air motor vs electrical motor is the torque. An air motor allows you to adjust the torque output depending on your needs. Air motors feature a dynamically generated torque load. Electric motors get their power, either, from an Alternating Current (AC) or Direct Current (DC) motor.

##### **5. What is chattering in pressure valve? May/June 2014**

Chattering is the rapid opening and closing of a pressure-relief valve. The resulting vibration may cause misalignment, valve seat damage, and, if prolonged, mechanical failure of valve internals and associated piping.

**6. List the three types proportional control valve May/June 2012**

- i) Solenoid Operated Proportional Relief Valve.
- ii) Solenoid Operated Proportional Relief Valve.
- iii) Direct Operated Type Solenoid Operated Proportional Throttle Valve.

**7. What is tandem cylinder? April/May 2015**

It design has two cylinders mounted in line with pistons connected by a common piston rod. These cylinders provide increased output force when the bore size of a cylinder is limited. But the length of the cylinder is more than a standard cylinder and also requires a larger flow rate to achieve a speed because flow must go to both pistons.

**8. Draw the ANSI symbol for Pilot operated check valve and Shuttle valve (April/May2008)**

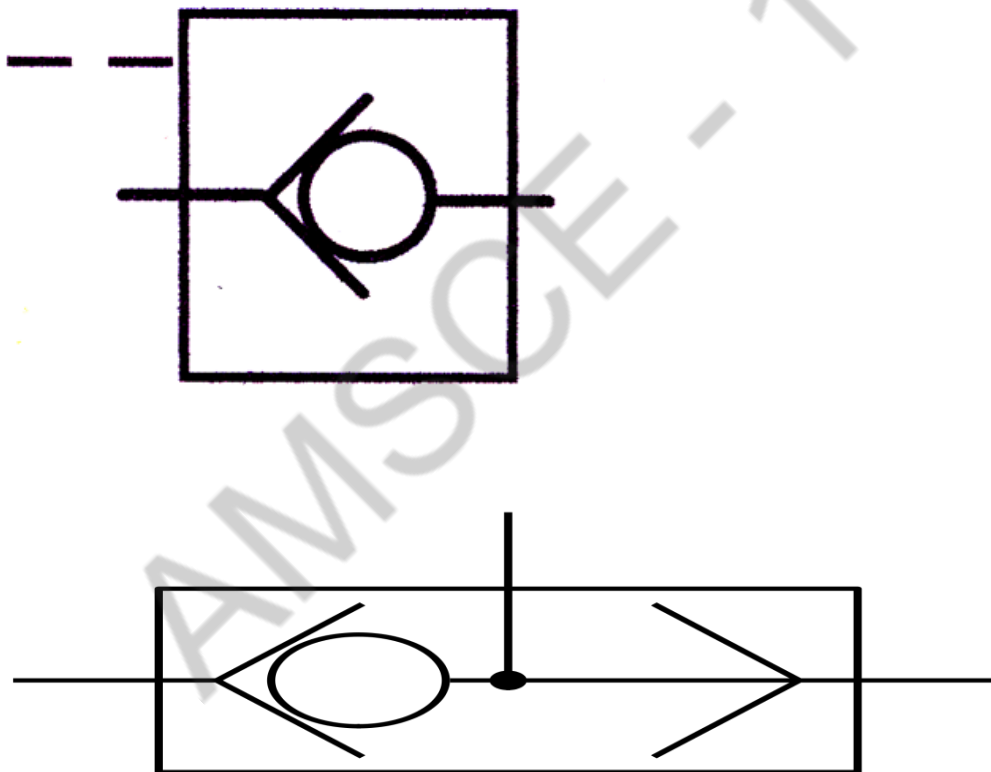

### **9. When is lobe pump is preferred? (Nov/Dec 2009)**

A lobe pump itself does not compress the material it pumps. Lobe pumps are frequently used in food applications because they handle solids without damaging the product. Particle size pumped can be much larger in lobe pumps than in other positive displacement types

Rotary lobe pumps are non-contacting and have large pumping chambers, allowing them to handle solids such as cherries or olives without damage. They are also used to handle slurries, pastes, and a wide variety of other liquid.

### **10. Why is end cushioning provided in hydraulic cylinder operation? (Nov/Dec 2009)**

Cushioning of some sort normally is required to decelerate a cylinder's piston before it strikes the end cap. Reducing the piston velocity as it approaches the end cap lowers the stresses on cylinder components and reduces vibration transmitted to the machine structure.

### **11. What is pressure compensated flow control? (April/May2010)**

A pressure-compensated flow control valve has a fixed throttling flow at all pressures. The two-way pressure-compensated flow control valve is also called a series valve. The pressure reducing valve and the smothering of this valve are placed in series with each other.

### **12. How does a servo valve difference from proportional valve (April/May 2010)**

Servo valve — any continuously variable, electrically modulated, directional control valve with less than 3% center overlaps.

Proportional valve — any continuously variable, electrically modulated, directional control valve with more than 3% center overlaps.

### **13. How do you classify directional control valve? (Nov/Dec 2005)**

Based on the number of ports present, the DCVs are classified as :

- (i) Two way valves,
- (ii) Three way valves, and
- (iii) Four way valves.

14. Draw the symbol of pressure relief valve (Nov/Dec 2005)

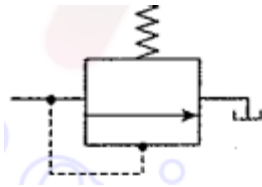

15. Give the hydraulic symbol for  $\frac{3}{4}$  closed centre solenoid DCV (May/June 2006)

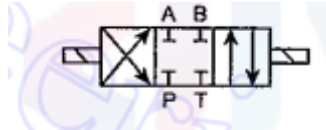

16. What is the difference between pilot operated and direct operated pressure relief valve (May/June 2006)

Direct operated pressure relief valves are used where the flow rate and the system pressure are reasonably smaller or there is not much variation in system pressure or flow rate. Whereas for a larger flow rate and higher pressure, pilot operated pressure relief valves are used. The great advantage of pilot valve is that it can be kept spatially separated from the main valve.

17. Difference between pressure control valve and pressure relief valve (Nov/Dec 2006)

Pressure control valve controls the fluid pressure in a system whereas pressure relief valve protects a system from excessive fluid pressure over and above the design pressure limit.

18. write the function of solenoid valve(Nov/Dec 2006)

A solenoid is an electromagnetic mechanical transducer that converts an electrical signal into a mechanical output force. It provides a push or pull force to remotely operate fluid

19. define pressure over ride in pressure control valve (Nov/Dec 2006)

The pressure at which the valve opens is called the cracking pressure. The cracking and closing pressure of the control valve is not same. Moreover in most cases, the valve poppet cracks at a pressure lower than the adjusted pressure but the valve closes at a lower pressure than at which it cracks. This phenomenon is known as pressure override.

20. What is the control function of different valves in hydraulic system (Nov/Dec 2007)

1. *Directional control valves:* To control the direction of flow by which the direction of actuator is controlled.
2. *Pressure control valves:* To control the pressure of the fluid in the circuit by which the force exerted by actuator is controlled.
3. *Flow control valves:* To control the flowrate of fluid in the circuit by which the speed of the actuator is controlled.

AMSCCE - 1101

## PART-B

### UNIT-II

1. i) Explain with neat sketch, the principle and operation of telescopic cylinder (April/May 2008)

They are used where long work strokes are needed. A telescopic cylinder provides a relatively long working stroke for an overall reduced length by employing several pistons which telescope into each other.

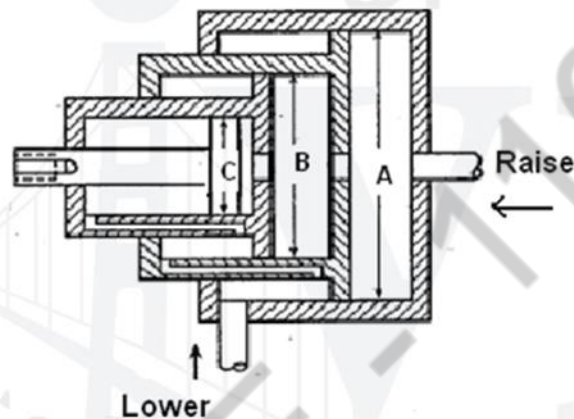

Since the diameter A of the ram is relatively large, this ram produces a large force for the beginning of the lift of the load. When ram A reaches the end of the stroke, ram B begins to move. Now ram B provides the required smaller force to continue raising the load. When ram B reaches the end of its stroke, then ram C moves outwards to complete the lifting operation. These three rams can be retracted by gravity acting on the load or by pressurized fluid acting on the lip of each ram.



ii) With respect the hydraulic motors. Define the terms Volumetric, Mechanical and Overall efficiency (April/May 2008)

#### 6.14. HYDRAULIC MOTOR PERFORMANCE

Like in hydraulic pumps, the performance of hydraulic motor is also evaluated by using volumetric, mechanical, and overall efficiencies.

##### 6.14.1. Volumetric Efficiency ( $\eta_{vol}$ )

The volumetric efficiency of a hydraulic motor is the inverse of that for a pump. Mathematically,

$$\eta_{vol} = \frac{\text{Theoretical flow rate motor should consume}}{\text{Actual flow rate consumed by motor}} \times 100 = \frac{Q_T}{Q_A} \times 100 \dots (6.11)$$

##### 6.14.2. Mechanical Efficiency ( $\eta_{mech}$ )

The mechanical efficiency of a hydraulic motor is the inverse of that for a pump. Mathematically,

$$\eta_{mech} = \frac{\text{Actual torque delivered by motor}}{\text{Torque motor should theoretically deliver}} \times 100 = \frac{T_A}{T_T} \times 100 \dots (6.12)$$

where  $T_A = \frac{\text{Actual power delivered by motor (watts)}}{\text{Angular speed of motor shaft (rad/s)}} = \frac{P}{\omega}$ , and

$$T_T = \frac{V_D (m^3/rev) \times P (N/m^2)}{2\pi} \dots (6.13)$$

##### 6.14.3. Overall Efficiency ( $\eta_o$ )

The overall efficiency of the hydraulic motor is the product of the volumetric and mechanical efficiencies. Mathematically,

$$\eta_o = \eta_{vol} \times \eta_{mech} \dots (6.14)$$

Combining equations (6.11), (6.12), (6.13), and (6.14), we get

$$\eta_o = \frac{T_A (N-m) \times \omega (rad/s)}{P (N/m^2) \times Q_A (m^3/s)} \times 100 \dots (6.15)$$

**Note** The actual power delivered to a motor by the fluid is called by the term 'hydraulic power'. Similarly, the actual power delivered to a load by a motor via a rotating shaft is called 'brake power'.

## 2. Explain the sequencing of two double acting cylinders with a neat sketch. (April/May 2008)

Fig.6.4 illustrates the arrangement of a typical telescoping type cylinder having three rams.

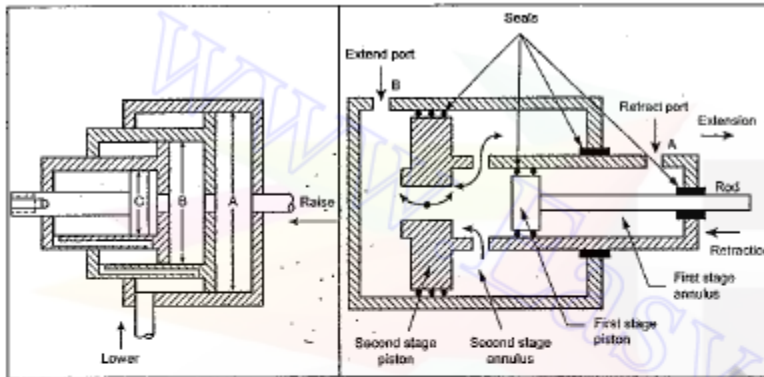

Fig. 6.4. Telescoping cylinder

Fig. 6.5. Operation of a two-stage double-acting telescopic cylinder

Since the diameter A of the ram is relatively large, this ram produces a large force for the beginning of the lift of the load.† When ram A reaches the end of the stroke, ram B begins to move. Now ram B provides the required smaller force to continue raising the load. When ram B reaches the end of its stroke, then ram C moves outwards to complete the lifting operation. These three rams can be retracted by gravity acting on the load or by pressurized fluid acting on the lip of each ram.

### 6.6.3. Working of a Two-Stage Double-Acting Telescopic Cylinder

Fig.6.5 illustrate the operation of a typical two-stage double-acting telescopic cylinder.

**Retraction stroke :** During the retraction stroke, the fluid is fed into the first-stage annulus via retract port A. Therefore the first stage piston is forced to the left until it uncovers the fluid ports connecting this with the second stage annulus. This, in turn, moves the larger piston to the left until both the pistons are fully retracted into the body of the cylinder.

**Extension stroke :** During the extension stroke, the fluid is fed through the extend port B. Now the fluid forces both pistons to the right until the cylinder is fully extended.

As could be seen from Fig.6.5 that many seals are provided for preventing any possible fluid leakages.

**3. With a neat sketch describe the construction and operation of a pressure compensated flow control valve (April/May 2008)**

The construction and operation of a typical pressure-compensated flow control valve is illustrated in Fig.7.24.

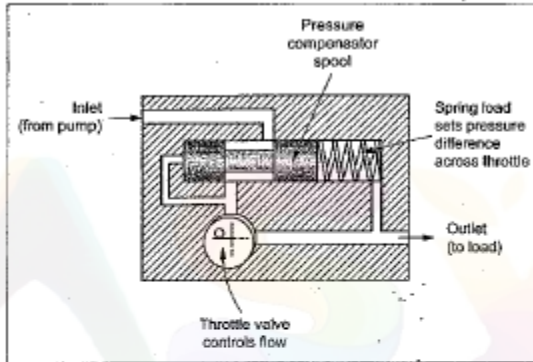

Fig. 7.24. Pressure-compensated flow control valve

The valve actually has two main parts arranged in series. They are :

**1. Throttle valves :** Similar to a needle valve, the throttle valve has an orifice whose area can be adjusted by an external knob setting. This throttle valve setting determines the flow rate is to be controlled.

**2. Pressure compensator :** The pressure compensator spool controls the size of the inlet orifice and maintains a constant pressure drop across the throttle valve.

As inlet pressure increases and overcomes the spring force, the pressure compensator spool closes the inlet passage. It blocks off all flow in excess of the throttle setting. As a result, the valve permits the fluid flow only to the amount for which the throttle is already set.

When the fluid passes through the throttle valve, the pressure builds up in the spring side of the compensator. This pressure drop produces a rapid compensation in the form of spool motion. This spool adjustment causes the pressure drop to return quickly to its original value, thus maintaining constant flow.

**4. Discuss the construction and working of a solenoid-actuated valve (Nov/Dec 2009)**

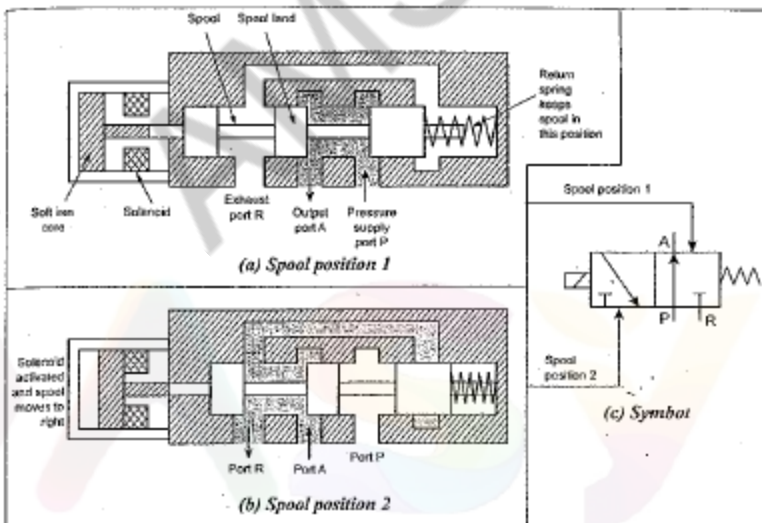

Fig. 7.11. Construction and operation of a solenoid-actuated 3/2 valve

As shown in Fig.7.11(a) and (b), the valve is actuated by a current passing through a solenoid and, returned to its original position by a spring. The spool slides over the finely finished valve bore inside the valve housing.

**Spool position 1 :** In the original or neutral position of the spool, (Fig.7.11(a)), the pressurized fluid flows from port P to port A to move the actuator, the exhaust port (R) remaining closed.

**Spool position 2 :** When the solenoid is activated (Fig.7.11(b)), the spool moves to the extreme left. In the extreme spool position, the fluid from port P gets closed and hence the fluid is permitted to flow from port A to port R.

Thus the valve alternately connects and disconnects fluid supply to the cylinder by the sliding spool.

**5. Discuss the functioning of an unloading valve with a diagram (Nov/Dec 2009)**

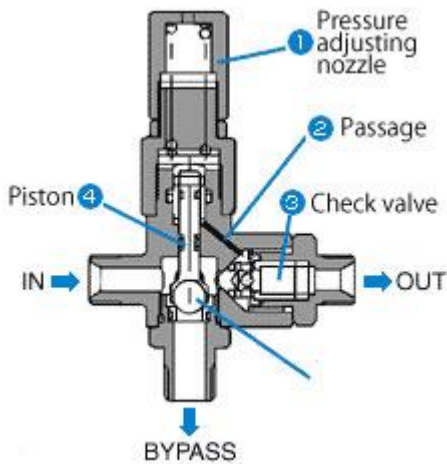

Unloading valves are pressure-control devices that are used to dump excess fluid to tank at little or no pressure. A common application is in hi-lo pump circuits where two pumps move an actuator at high speed and low pressure, the circuit then shifts to a single pump providing high pressure to perform work.

the construction of a direct-acting unloading valve. The valve consists of a spool held in the closed position by a spring. The spool blocks flow from the inlet to the tank port under normal conditions. When high-pressure fluid from the pump enters at the external-pilot port, it exerts force against the pilot piston. (The small-diameter pilot piston allows the use of a long, low-force spring.) When system pressure increases to the spring setting, fluid bypasses to tank (as a relief valve would function). When pressure goes above the spring setting, the spool opens fully to dump excess fluid to tank at little or no pressure.

A pilot-operated unloading valve has less pressure override than its direct-acting counterpart does, so it will not dump part of the flow prematurely. It also will go from no flow to maximum flow quickly, thus using all the flow from the high-volume pump flow for a longer period, and rapidly dropping horsepower draw from the high-volume pump.

In a pilot-operated unloading valve, the unloading spool receives a signal through the remote-pilot port when pressure in the working circuit goes above its setting. At the same time, pressure on the spring-loaded ball in the pilot section starts to open it. Pressure drop on the front side of the

unloading spool lowers back force and pilot pressure from the high-pressure circuit forces the spring-loaded ball completely off its seat. Now there is more flow going to tank than the control orifice can keep up with. The main poppet opens at approximately 20 psi. Now, all high-volume pump flow can go to tank at little or no pressure drop and all horsepower can go to the low volume pump to do the work. When pressure falls approximately 15% below the pressure set in the pilot section, the spring-loaded ball closes and pushes the unloading spool back for the next cycle.

**6. With a neat sketch, explain the construction and cushioning mechanism in cylinder (Apr/May 2010) (May/June2012), (May/June2014)(April/May2010)**

#### **6.5.1. What is Meant by Cylinder Cushion ?**

When the pressurised fluid is allowed to enter inside the cylinder, the piston accelerate and travels in the cylinder barrel. If the piston is allowed to travel at the same speed till the end of the stroke, it will hit the end cap with a great impact. To avoid this impact, the piston needs to decelerate at the end of the travel. The arrangement made at the end caps to achieve the same is called 'cylinder cushion'.

#### **6.5.2. Construction and Operation**

A typical cylinder cushioning arrangement is illustrated in Fig.6.3. Figs.6.3(a) and (b) show the position of the piston at the start and of the cushioning action, respectively.

As the piston approaches the end of its stroke, the plunger enters the end cap port and thus blocks the free flow. Now the fluid is trapped between the piston and the end cap. This fluid can escape only by passing through the adjustable restrictor, as shown in Fig.6.3(b). This fluid flow through the restricted flow path causes the piston to decelerate. The rate of deceleration of the piston can be controlled by the adjustable needle valve. A non-return or check valve is provided to allow free flow of fluid to the cylinder quickly during the return stroke.

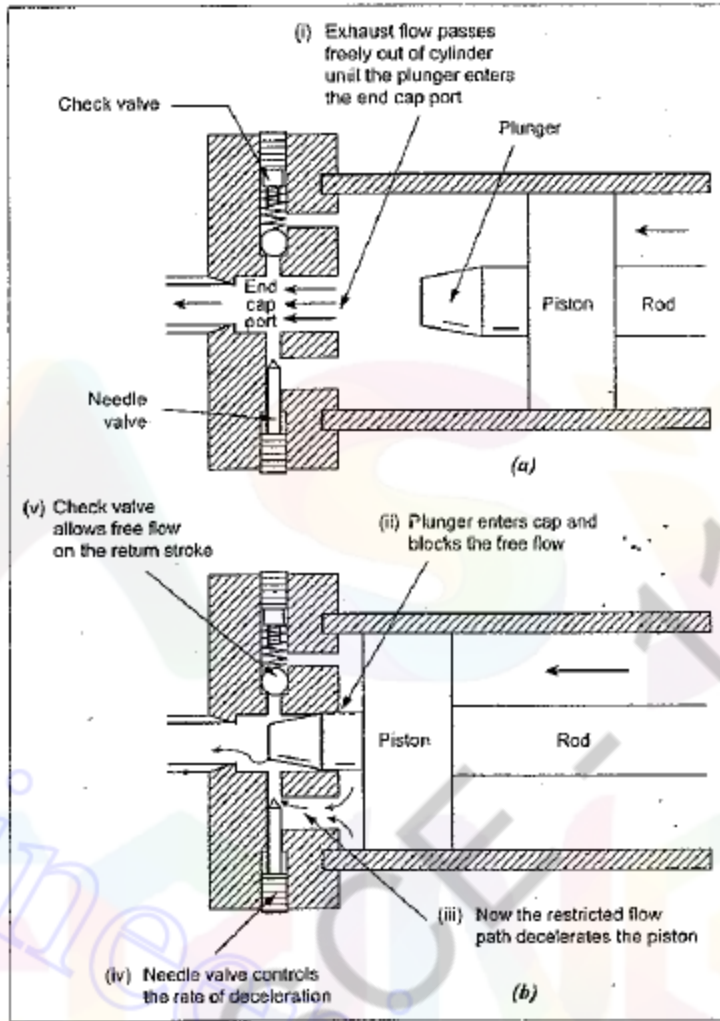

## 7. Explain the construction of pressure relief valve with neat sketch May/June 2012

### 7.14. SIMPLE (OR DIRECT ACTING) PRESSURE RELIEF VALVE

#### 7.14.1. Construction and Operation

The construction and operation of a simple poppet (ball)-type direct-acting pressure valve is illustrated in Fig. 7.16(a). It has one inlet port which is normally closed under the influence of spring force. An adjustable spring load provides the pressure setting of the relief valve.

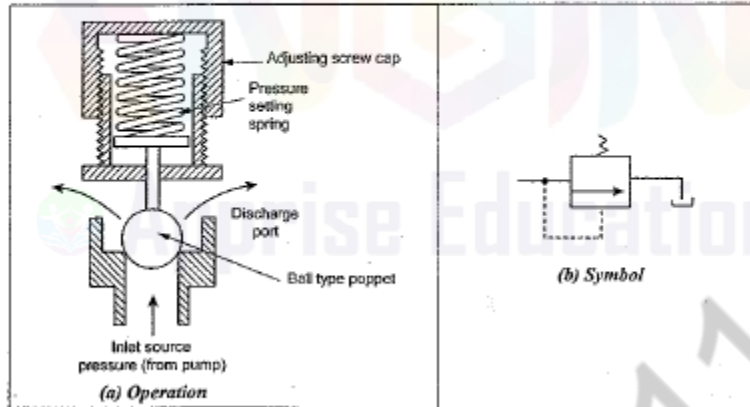

Fig. 7.16. Simple pressure relief valve

When the inlet pressure overcomes the force exerted by the spring, the valve opens and vents to the atmosphere or back to the sump. Thus the relief valve protects the other elements in the system from excessive pressure by diverting the excess fluid to the sump or atmosphere when the system pressure tends to exceed the preset level.

The direct-acting type of relief valves have a ball, poppet or a sliding spool working against a spring. As the inlet pressure decreases, the valve closes again. The adjusting screw cap is used to adjust the pressure limit and to vary the spring force.

#### 7.14.2. Graphic Symbol

Fig. 7.16(b) represents the graphic symbol of simple relief valve.

#### 7.14.3. Application of Simple Relief Valves

The direct-acting pressure relief valves are used where the flow rate and the system pressure are low.

#### 7.14.4. Limitation of Simple Relief Valves

When the required system pressure is high, a heavier spring is required. Because of the use of heavier spring, the problem of valve chatter or pressure fluctuations are very common.

## 8. Explain the operation of a check valve with a neat sketch (Nov/Dec 2011)

### 7.7. CHECK VALVES (OR TWO WAY VALVES)

#### 7.7.1. Introduction

- ✓ Check valves are the most commonly used and the simplest type of directional control valves.
- ✓ The check valve is a *two-way valve* because it contains two ports. Also a *check valve is analogous to a diode in electric circuits.*
- ✓ **Functions :** The check valves are used :
  - (i) to allow free flow in only one direction, and
  - (ii) to prevent any flow in the other direction.
- ✓ Since check valves block the reverse flow of the fluid, they are also known as *non-return valves.*
- ✓ The symbolic representation of a check valve, shown in Fig.7.4, illustrates its function clearly.

#### 7.7.2. Types of Check Valves

Check valves are of several types. But the two important types of check valves are :

1. Poppet-type check valves, and
2. Pilot-operated type check valves.

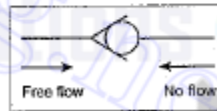

Fig. 7.4. Symbolic representation of a check valve

#### 7.7.3. Poppet-Type (or Simple) Check Valves

##### 7.7.3.1. Construction and Operation

The construction and operation of a typical poppet type check valve is illustrated in Fig.7.5. Normally a spring holds the poppet in the closed position.

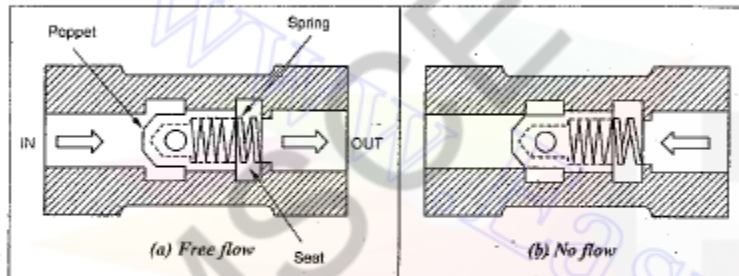

Fig. 7.5. Construction and operation of a poppet-type check valve

When flow is in the normal direction, the liquid pressure acts against the spring tension to hold the poppet offset the seat. When the liquid pressure overcomes the spring force, as shown in Fig.7.5(a), the valve allows the free flow. When flow stops, the spring seats the poppet and liquid cannot pass in the reverse direction.

Instead, if flow is attempted in the opposite direction as shown in Fig.7.5(b), the liquid pressure along with the spring force pushes the poppet in the closed position. Hence no flow is permitted in opposite direction.

##### 7.7.3.2. Applications of Simple Check Valves

Usually poppet type check valves are used to provide the pilot pressure to operate larger valves.

#### 7.7.4. Pilot-Operated Check Valves

The piloted operated check valve allows free fluid flow in one direction, but reversed flow depends upon the pilot actuation. That means, this type check valve also allows the reverse flow, provided pilot pressure is applied at the pilot pressure port of the valve to overcome the spring force of the poppet.



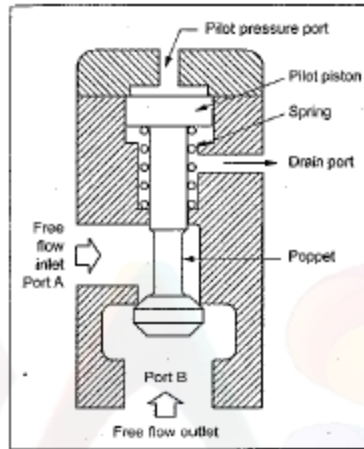

Fig. 7.6. Pilot-operated check valve

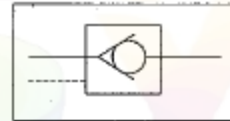

Fig. 7.7. Symbolic representation of a pilot-operated check valve

In order to permit the fluid flow in the reverse direction *i.e.*, from port B to port A, a pilot pressure is applied through the pilot pressure port. The pilot pressure pushes the pilot piston and the poppet down. Thus the fluid flow in the reverse direction is also obtained. The purpose of the drain port in the circuit is to prevent oil from creating a pressure buildup on the bottom of the pilot piston.

#### 7.7.4.2. Graphical Symbol

Fig.7.7 shows the symbolic representation of a pilot-operated check valve. In Fig.7.7, the dashed line presents the pilot pressure line.

#### 7.7.4.3. Applications of Pilot-Operated Check Valves

The pilot-operated check valves are widely used to hydraulically lock the cylinders such as in a hydraulic jack.

## 9. Explain the working of a pilot operated pressure relief valve with neat sketch (Nov/Dec2012)

### 7.15. COMPOUND (OR PILOT-OPERATED) PRESSURE RELIEF VALVE

#### 7.15.1. Introduction

The compound pressure relief valve overcomes the problem of direct-acting pressure relief valve. Thus these relief valves can be employed for a larger flow rate and higher system pressure. These valves are built in two stages.

#### 7.15.2. Construction and Operation

The construction of a typical sliding-spool type pilot-operated pressure relief valve is illustrated in Fig.7.17.

This compound relief valve operates in two stages :

**Stage 1 :** The first stage is the same as direct-acting type. As in the direct-acting type, the movable main poppet allows fluid to escape to the reservoir when the system pressure exceeds the setting of the valve. This first stage is shown on the right side of the valve. The main poppet is retained to its seal by a light spring.

**Stage 2 :** The second stage, also known as *pilot stage*, is located on the left side of the valve. It contains a pilot valve poppet (also known as control poppet) which is held against a seat by an adjustable strong spring. The pressure limit can be adjusted by using an adjustment screw.

The inlet system pressure acts on both sides of the main poppet because of the small orifice shown in Fig.7.17. The fluid passes from the inlet port through the orifice to a control chamber where it acts on the main poppet to add to the spring force. The system pressure also acts on the pilot poppet as shown in Fig.7.17.

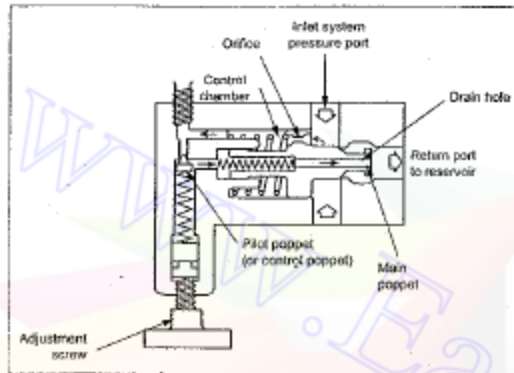

Fig. 7.17. Pilot-operated pressure-relief valve

When the system pressure exceeds the setting pressure of the main poppet, the poppet is pushed from its seat towards left. This forces the pressurised fluid on the left side to escape through the centrally drilled drain hole of the main poppet. This limits the pressure on the control chamber side. Due to the restricted flow through the orifice, the fluid cannot enter into the control chamber as quickly as the fluid leaves through the drain hole. Because of this, the pressure on the right side exceeds that on the left and the main poppet moves to the left. Thus it permits the fluid flow directly to the reservoir tank from the inlet port. When the pressure falls below the setting pressure, the main poppet retracts back to its original position again.

## 10. Write the short notes on (May/June2012)

### i) Direct acting pressure reducing valve

#### 7.17. DIRECT-ACTING PRESSURE REDUCING VALVE

##### 7.17.1. Construction and Operation

The construction and operation of a direct-acting pressure reducing valve is illustrated in Fig.7.18(a). It has a spring loaded spool to control the downstream (outlet) pressure.

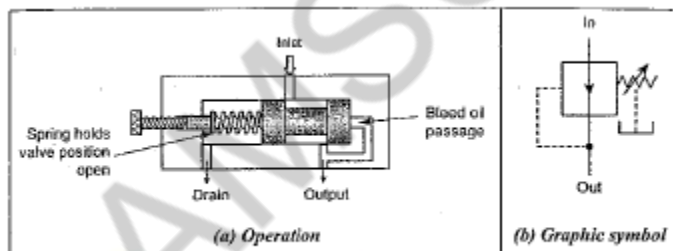

Fig. 7.18. Pressure reducing valve

When the main supply pressure is below the valve setting pressure, fluid will flow freely from the inlet to the outlet. It can be noted from Fig.7.18 that an internal connection from the outlet passage transmits the outlet pressure to the spool end opposite the spring.

When the downstream (outlet) pressure increases to the valve setting pressure, the spool moves to the left to partly block the outlet port. During this period, only enough flow is passed to the outlet to maintain the preset pressure.

If the valve closes completely, leakage could cause the spool pressure to build up. In order to avoid this, a continuous bleed to the tank is permitted to keep the valve slightly open. A separate drain passage is provided to drain this fluid to the tank.

## ii) Pilot operated sequence valve

### 7.19. SEQUENCE VALVES

#### 7.19.1. What are Sequence Valves

- ✓ The sequence valves are used to control the fluid flow to ensure several operations in a particular order of priority in the system.
- ✓ The sequence valves are another type of pressure control valves, which are also extensively used in hydraulic systems.
- ✓ These valves permit several operations to be completed in a sequential order, i.e., one after another. For example, a pressure sequence valve used in a clamping and drilling circuit will permit the clamping operation to take place first and then the drilling operation is accomplished.
- ✓ The sequence valves are set to specific pressure levels so as to ensure the priorities of function.

#### 7.19.1.1. Types of Sequence Valves

Sequence valves are basically relief valves with minor modifications and may be either of the direct-acting or compound type.

#### 7.19.2. Pilot-Operated (or Compound) Sequence Valve

The construction and operation of a typical pilot-operated sequence valve is illustrated in Fig.7.19(a).

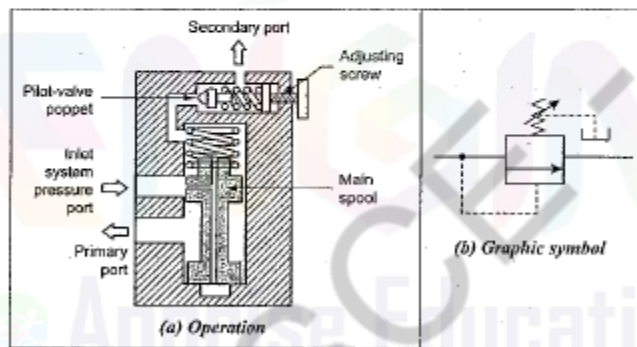

Fig. 7.19. Pilot operated sequence valve

When the system inlet pressure is within the preset valve pressure, the valve allows the fluid freely through the primary port to operate the first phase. When the system inlet pressure exceeds the preset valve pressure, the valve spool moves up. As the spool lifts, flow is diverted to the secondary port to operate the second phase.

The required sequential pressure can be adjusted with the help of the adjusting screw.

**11. Explain any three types of cylinders used in hydraulics with neat sketch (April/May2008)**

**DOUBLE ROD CYLINDER:**

It is a cylinder with single piston and a piston rod extending from each end. This cylinder allows work to be performed at either or both ends. It may be desirable where operating speed and return

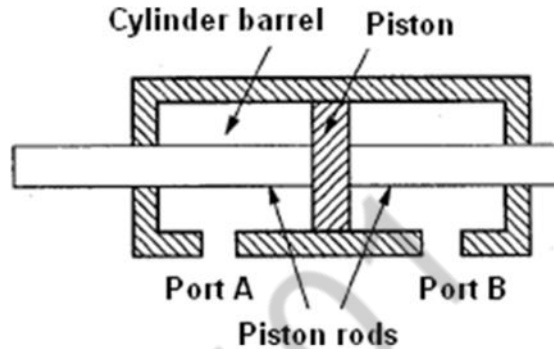

**TANDEM CYLINDER:**

Its design has two cylinders mounted in line with pistons connected by a common piston rod. These cylinders provide increased output force when the bore size of a cylinder is limited. But the length of the cylinder is more than a standard cylinder and also requires a larger flow rate to achieve a speed because flow must go to both pistons.

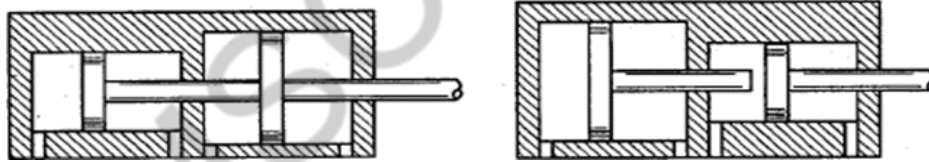

## TELESCOPIC CYLINDER

They are used where long work strokes are needed. A telescopic cylinder provides a relatively long working stroke for an overall reduced length by employing several pistons which telescope into each other.

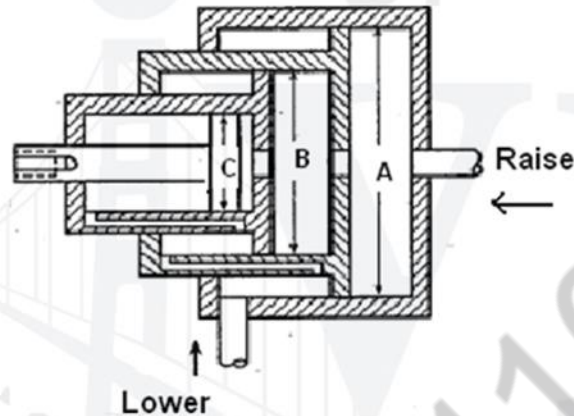

Since the diameter A of the ram is relatively large, this ram produces a large force for the beginning of the lift of the load. When ram A reaches the end of the stroke, ram B begins to move. Now ram B provides the required smaller force to continue raising the load. When ram B reaches the end of its stroke, then ram C moves outwards to complete the lifting operation. These three rams can be retracted by gravity acting on the load or by pressurized fluid acting on the lip of each ram.

## 12. Discuss the working of gear motor with neat sketch (May/June 2014)

### 6.10. GEAR MOTORS

#### 6.10.1. Introduction

Like gear pumps, gear motors are fixed displacement devices. Also, gear motors can be classified as external or internal gear units. External gear motors include the gear-on-gear

units such as the spur gear motor. Internal gear motors include the crescent seal types and the gerotor type unit.

#### 6.10.2. Construction and Operation

Fig.6.9 illustrates the operation of a gear motor. In this type, both the gear wheels are driven and one of the gear wheel has an extended shaft to provide output torque.

In the gear motor, rotary motion is produced by the unbalanced hydraulic forces on the gear teeth. The hydraulic imbalance in a gear motor is caused by gear teeth unmeshing. As gear teeth unmesh, all teeth subjected to system pressure are hydraulically balanced, except for one side of one tooth on one gear. This imbalance of force on gears, as shown in Fig.6.9, develops the torque. It should be noted that the larger the gear tooth or higher the pressure, more is the torque produced.

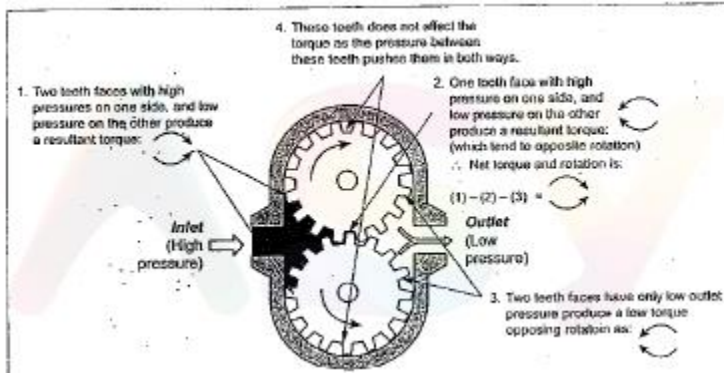

AMSCCE-1101

## UNIT III

### HYDRAULIC CIRCUITS AND SYSTEMS

#### PART-A

##### **1. List the application of intensifier. Nov/Dec2011, Nov/Dec 2012**

- i) It is required in hydraulic machines such as hydraulic presses which require fluid at high pressure.
- ii.) Intensifier is used commonly for clamping, holding, punching, presses, jacks, torque wrenches.

##### **2. List the basic arrangements in hydrostatic drives. May/June2013**

The operating principle of hydrostatic transmissions (HSTs) is simple: A pump, connected to the prime mover, generates flow to drive a hydraulic motor, which is connected to the load. If the displacement of the pump and motor are fixed, the HST simply acts as a gearbox to transmit power from the prime mover to the load. Most HSTs, however, use a variable-displacement pump, motor, or both so that speed, torque, or power can be regulate.

##### **3. What is the function of accumulator? May/June2014**

Leakage compensation, auxiliary power source, emergency power source, shock suppressor, thermal expansion compensator.

##### **4. What is the function of accumulator? NOV/DEC 2014**

Accumulator is used as an auxiliary power source. It is a device which stores the potential energy of the fluid. The stored potential energy in the accumulator acts

**5. Define the terms Lap and Null With respect to the servo valves. (April/May2008)**

**Valve lap**, or valve overlap, refers to the amount of spool travel from the center position required to start opening between the powered input port and the work (output) port or the tank port. A zero lapped valve is one in which any tiny, differentially small amount of spool shift, either way, starts the opening. However, there is no contact between the OD of the spool and ID of the bore. And even zero lapped valves have some slight amount of overlap. Nonetheless, the zero-lapped term persists.

**Valve null** is a specific point of a servo valve's pressure metering curve where the two deadhead (blocked port) work port pressures are equal. Servo valves are equipped with a mechanical adjusting device so that with no electrical power applied (connector disconnected from the valve), a spring or magnetic force can be changed to make the two work port pressures equal. That is normally where the factory adjusts a valve during final test, assuming it will be used on an equal area cylinder.

**6. What is meant by an air over oil system? (April/May2008)**

Air-over-oil tanks are another common way to create an air-over-oil system. These tanks hold more than enough oil to stroke the cylinder one way. Having an air valve piped to the air-over-oil tanks forces oil from the tanks into the cylinder

**7. State Coanda effect (April/May2008)**

Coanda effect is the phenomena in which a jet flow attaches itself to a nearby surface and remains attached even when the surface curves away from the initial jet direction. In free surroundings, a jet of fluid entrains and mixes with its surroundings as it flows away from a nozzle.



## **8. What are the advantages of using intensifiers? (Nov/Dec 2009)**

- Higher performance and longer life on account of a lower operating pressure
- More compact system
- Greater safety due to lower pressure in general
- Integrated valves
- No dynamic seals
- Intensification ratio adapted to requirements

## **9. What is the purpose of synchronised hydraulic circuits? (Nov/Dec 2009)**

A hydraulic circuit is connected to the cylinder assemblies, and includes synchronizer with multiple isolated chambers corresponding to the lift cylinder assemblies, a rod extending axially through the chambers, and pistons mounted on the rod and associated with the isolated chambers. An axial passageway extends continuously through the rod and is connected to first passageways for communicating hydraulic fluid to one side of the chambers.

## **10. List any four applications of accumulators (April/May2010)**

Accumulators are also used for systems where thermal expansion could cause excessive pressure. Cylinders with blocked ports in a high ambient heat area can go to high pressure if there is no place for expanding fluid to go.

Another use for accumulators is as a barrier between two different fluids. The pump that uses hydraulic fluid keeps pressure on a circuit that uses water or another incompatible medium.

One supplier offers low-pressure accumulators as breathing devices for sealed reservoirs. This keeps airborne contaminants out of the hydraulic oil as the fluid level rises and falls.

## **11. What is a sequencing circuit? April/May2015**

Process control pneumatics is also called as sequencing. It means performing number of actions one after another which follows each other in a simple order or with an order determined by sensors.

12. Draw any one type of synchronizing circuit (April/May 2010)

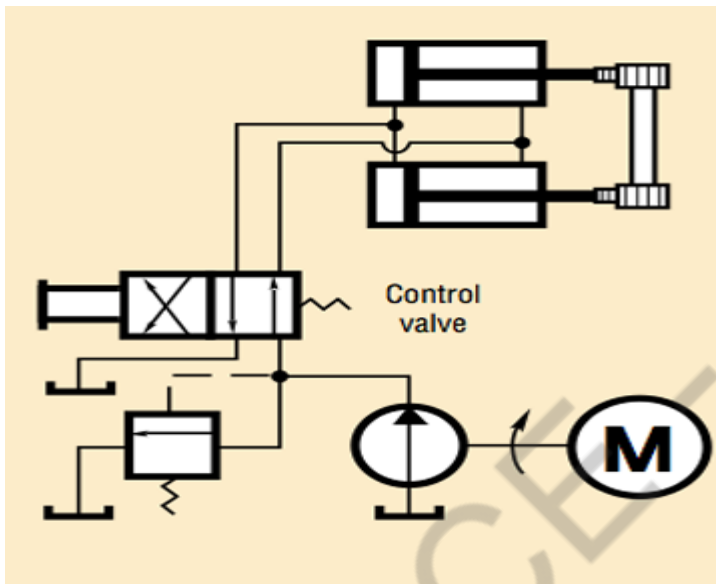

13. What is the function of regenerative circuits (Nov/Dec 2005)

The regenerative circuit is used to speed up the extending speed of a double-acting hydraulic cylinder.

14. What is servo valve? How does it work? (Nov/Dec 2005)

- ✓ Servo valves are nothing but DC valves having many stages of amplification capability.
- ✓ A servo system is one in which the comparatively large amount of power is controlled by small impulses or command signals and any errors are corrected by feedback signals.

15. Highlight the need of usage in accumulator (Nov/Dec 2006)

In hydraulic circuits, accumulators are used as:

- (i) Leakage compensator,
- (ii) Auxiliary power source,
- (iii) Emergency power source,
- (iv) Hydraulic shock absorber,
- (v) Fluid make-up device,
- (vi) Holding device, and
- (vii) Lubricant dispenser.

**16. What is twin pressure valve (Nov/Dec2005)**

Twin pressure valve, like counter balance valve, permits free flow in one direction and restricted flow in the opposite direction.

**17. What are major component of hydraulic system (Nov/Dec2007)**

- |                        |                          |
|------------------------|--------------------------|
| 1. Reservoir (or tank) | 4. Valves                |
| 2. Pump                | 5. Actuator              |
| 3. Prime mover         | 6. Fluid-transfer piping |

**18. What is an intensifier (Nov/Dec2007)**

Intensifier, also known as pressure intensifier or pressure booster, is a device used to compress the liquid in a hydraulic system to a value above the pump discharge pressure. It is analogous to a step-up electrical transformer.

**19. Name one application of a counterbalance valve. (Apr/May 2007)**

The counterbalance valve is used to maintain back pressure on a vertical cylinder to prevent it from falling due to gravity.

**20. What is the need for temperature compensation in flow control valves?**

As the viscosity of oil varies with temperature, the oil becomes less viscous when temperature increases. As the less viscous fluid flow more readily through an orifice, the increase in temperature causes increase in flow for a valve setting. So temperature compensation is needed to offset the effect of such temperature variation.

## UNIT III

### PART-B

#### 1. Draw and explain the hydraulic cylinder sequence circuits (April/May2005)

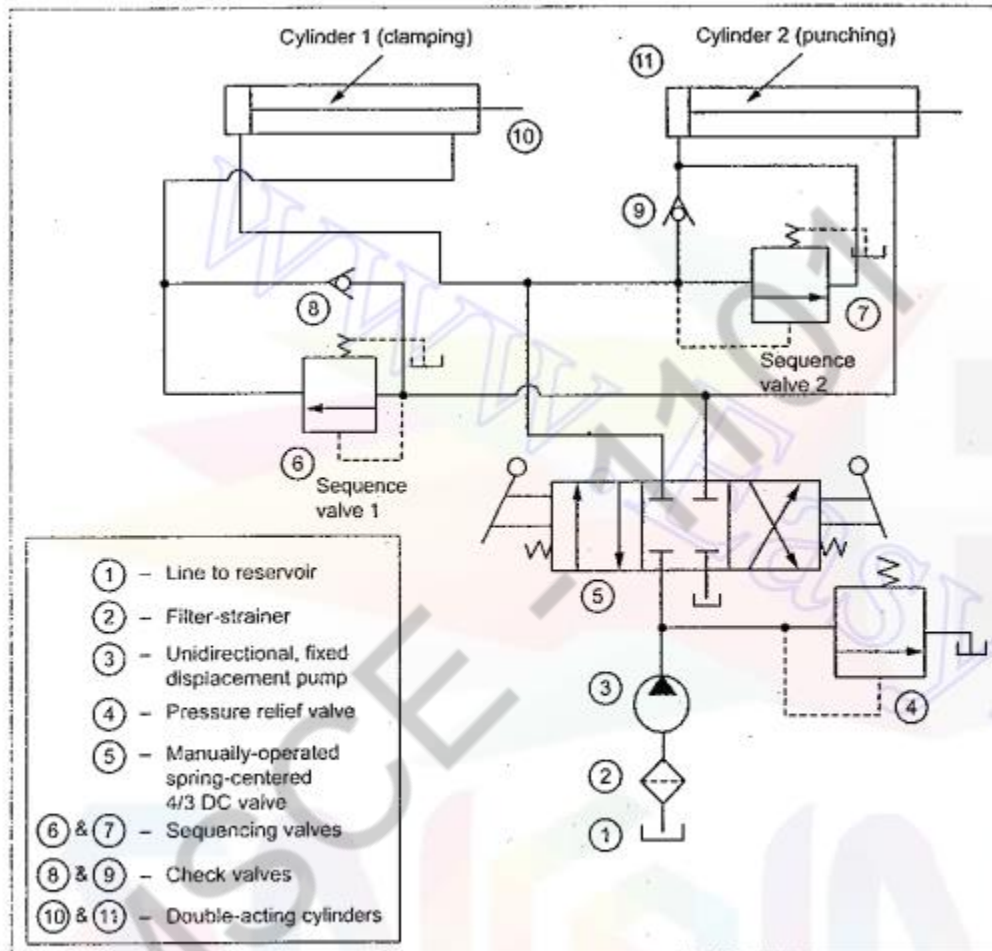

Fig. 13.5. Hydraulic cylinder sequence circuit (for clamping and punching operations)

#### 13.8.1. Circuit

Fig.13.5 illustrates a circuit that uses two sequence valves to control the sequence of operations of two double-acting cylinders. This circuit has a manually-operated, spring-centered 4/3 DC valve, two sequencing valves, two check valves, and a pressure relief valve. Let us take that cylinder-1 is used to clamp the workpiece and cylinder-2 is to perform punching; and the sequence of operation as clamping first and then punching.

**Spring-centered position :** When the 4/3 DC valve is shifted to the spring-centered position, the oil drains back to the tank through the pressure relief valve. Thus during the spring-centered position, both cylinders are hydraulically locked.

### 13.8.2. Operation

**Left mode position :** When the 4/3 DC valve is shifted manually to the left envelope flow path configuration, the cylinder-1 extends completely and the workpiece is clamped. Once the cylinder-1 reaches its end of the stroke, pressure is increased and sequence valve 1 opens and the oil starts to flow into the cylinder-2. Now the cylinder-2 extends to drive a spindle to do punching operation in the workpiece.

**Right mode position :** When the 4/3 DC valve is shifted to the right mode, the cylinder-2 retracts. Once the cylinder-2 retracts completely, the sequence valve 2 opens and the oil starts to flow into the cylinder-1. It causes the cylinder-1 to retract and hence the unclamping of workpiece is achieved.

## 2. Explain the working principles of a fail -safe circuits with over load protection (April/May2005)

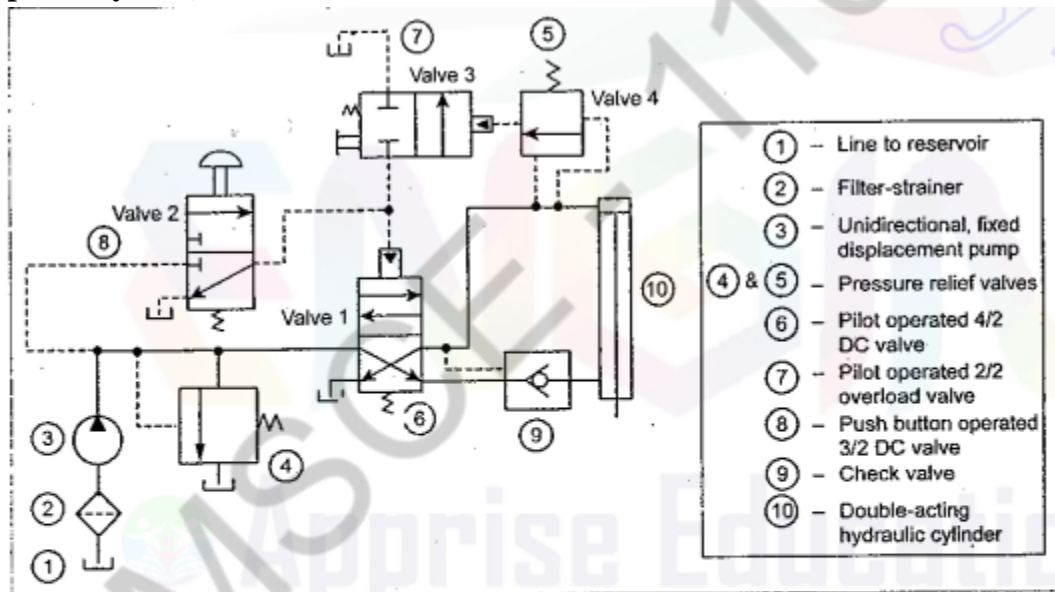

**Fig. 2. Fail-safe circuit with overload protection**

**Operation :** Push-button 3/2 valve (i.e., valve 2) controls the 4/2 DC valve (i.e., valve 1). When overload valve (i.e., valve 3) is shifted to its left mode, it drains the pilot line of valve 1. If the cylinder experiences excessive resistance during the extension stroke, sequence valve 4 pilot-actuates overload valve 3. This drains the pilot line of valve 1, causing it to return to its spring-offset mode. If an operator operates push button valve 2,

nothing will happen unless overload valve 3 is manually shifted to its blocked port configuration. Thus the system components are protected against overload during its extension stroke.

3. Describe an hydraulic circuits for synchronizing two cylinders with flow control valves (April/May2005)

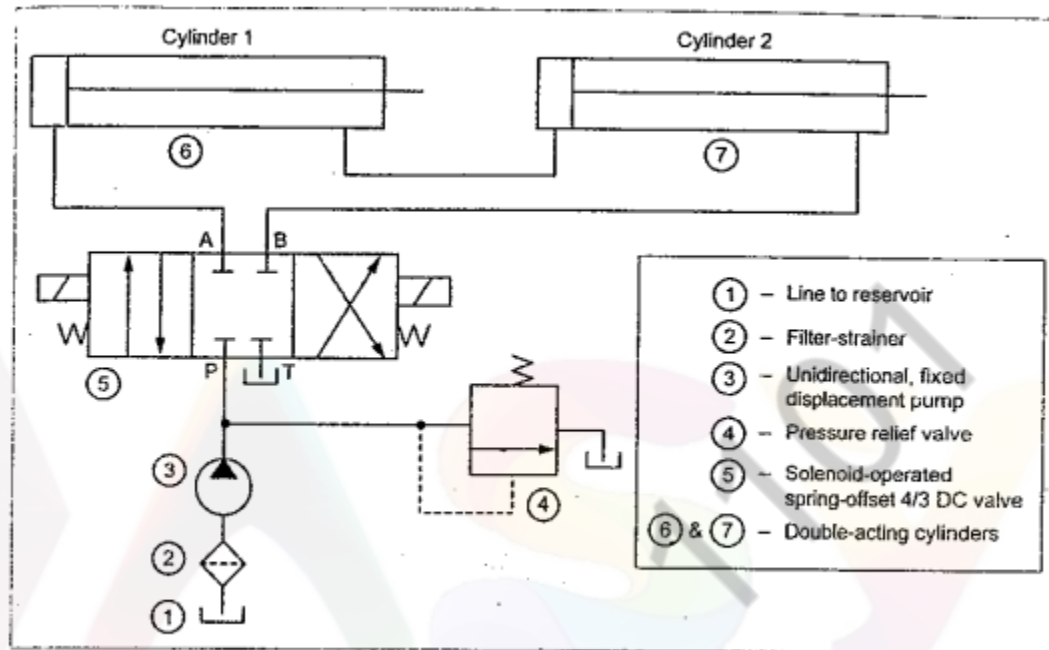

Fig. 13.7. Synchronizing hydraulic cylinders by connecting them in series

**Extension of cylinders 1 and 2 :** When the 4/3 DC valve is shifted to the left envelope flow path configuration, oil flows from the pump to the blind end of cylinder 1 and thus the cylinder 1 extends. At the same time, oil from the rod end of cylinder 1 is forced to the blind end of cylinder 2 and thus the cylinder 2 also extends. Now the oil returns to the tank from the rod end of cylinder 2 via the DC valve. Once full extension of cylinders 1 and 2 are over, the DC valve is shifted to the right mode.

**Retraction of cylinders 1 and 2 :** When the 4/3 DC valve is shifted to the right mode, oil flows from the pump to the rod end of cylinder 2 and thus the cylinder 2 retracts. At the same time, oil from the blind end of cylinder 2 is forced to the rod end of cylinder 1 and thus the cylinder 1 also retracts. Now the oil returns to the tank from the blind end of cylinder 1 via the DC valve.

Thus both extension and retraction operations of both cylinders are synchronized by connecting them in series. But for the two cylinders to be synchronized, the piston area of cylinder 2 should be equal to the difference between the areas of the piston and rod for cylinder 1.

4. Design a hydraulic sequence circuit for a milling machine with one cylinder for operating the power vice jaw and the other for controlling the cutler travel (April/May2005)

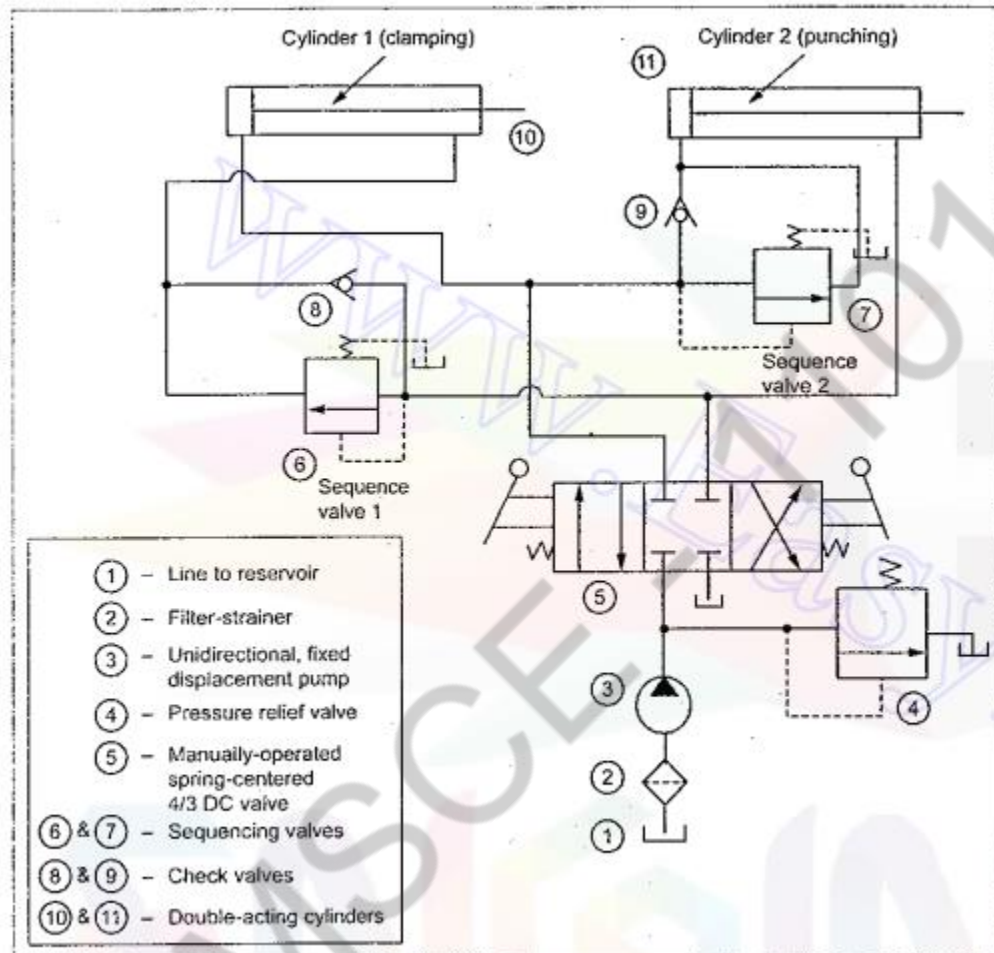

**Left mode position :** When the 4/3 DC valve is shifted manually to the left envelope flow path configuration, the cylinder-1 extends completely and the workpiece is clamped. Once the cylinder-1 reaches its end of the stroke, pressure is increased and sequence valve 1 opens and the oil starts to flow into the cylinder-2. Now the cylinder-2 extends to drive a spindle to do punching operation in the workpiece.

**Right mode position :** When the 4/3 DC valve is shifted to the right mode, the cylinder-2 retracts. Once the cylinder-2 retracts completely, the sequence valve 2 opens and the oil starts to flow into the cylinder-1. It causes the cylinder-1 to retract and hence the unclamping of workpiece is achieved.

5. Give any two application circuits employing accumulator for different purposes (May/June 2005)

8.11.3. Accumulator as Emergency Power Source

- ✓ In some hydraulic applications, it is necessary to retract the pistons of cylinders to their starting position (for safety reasons), even there may be an electrical power failure. In such applications, the accumulator can be used as an emergency power source to retract the piston of the cylinder.
- ✓ For example, consider a situation where a hydraulic system is operating a flood gate in a dam, and the electrical power fails. In such situation, the accumulator supplies the working fluid which operates the flood gate.

Fig.8.10 illustrates how gas-loaded accumulator can be used as emergency source of power. This circuit essentially has a solenoid-operated 3/2 DC valve.

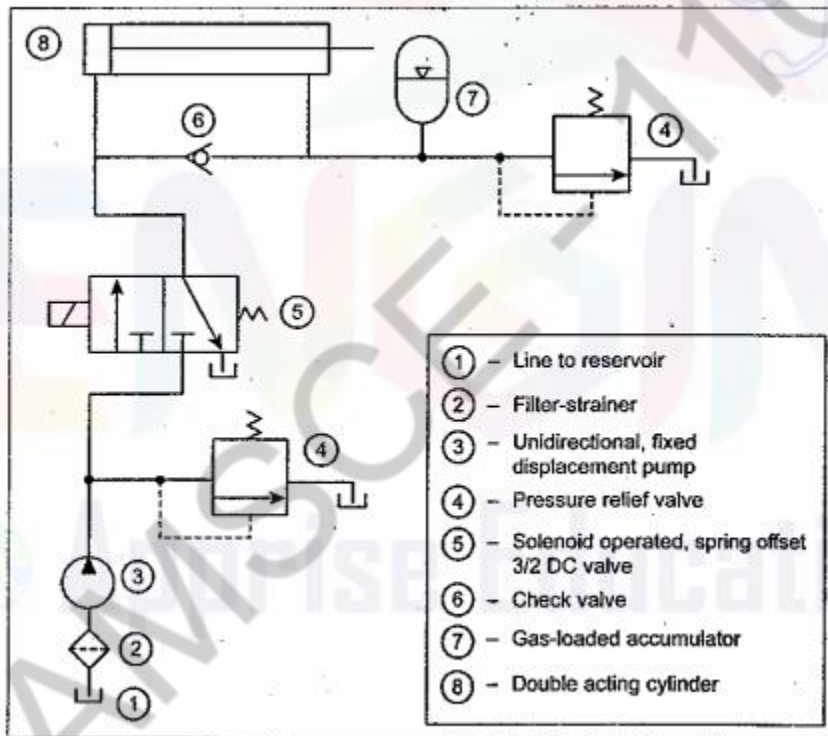

Fig. 8.10. Accumulator as an emergency power source



### 8.11.3.2. Operation

When operator depresses push button energizing solenoid of the 3/2 DC valve, oil flows to blind end of cylinder. At the same time, the oil also unseats check valve. So the oil under pressure flows to rod end of cylinder and into the accumulator. Now the accumulator charges the oil as the piston of cylinder extends.

When there is a power failure, the solenoid will deenergize. In the absence of solenoid-energy, the spring pressure forces the valve to shift to its spring-offset mode. Now the oil stored under pressure is forced from the bladder-type accumulator to the rod end of the cylinder. Thus the piston of the cylinder retracts to the starting position.

### 8.11.4. Accumulator as Hydraulic Shock Absorber

In many high-pressure hydraulic systems, the sudden stoppage or deceleration of a hydraulic fluid flowing at high velocity in pipelines can cause considerable damage to the piping. This hydraulic shock, also known as water hammer, may snap heavy pipes, loosen fittings and cause leaks. By installing an accumulator, this high-pressure pulsations or hydraulic shocks can be suppressed/absorbed.

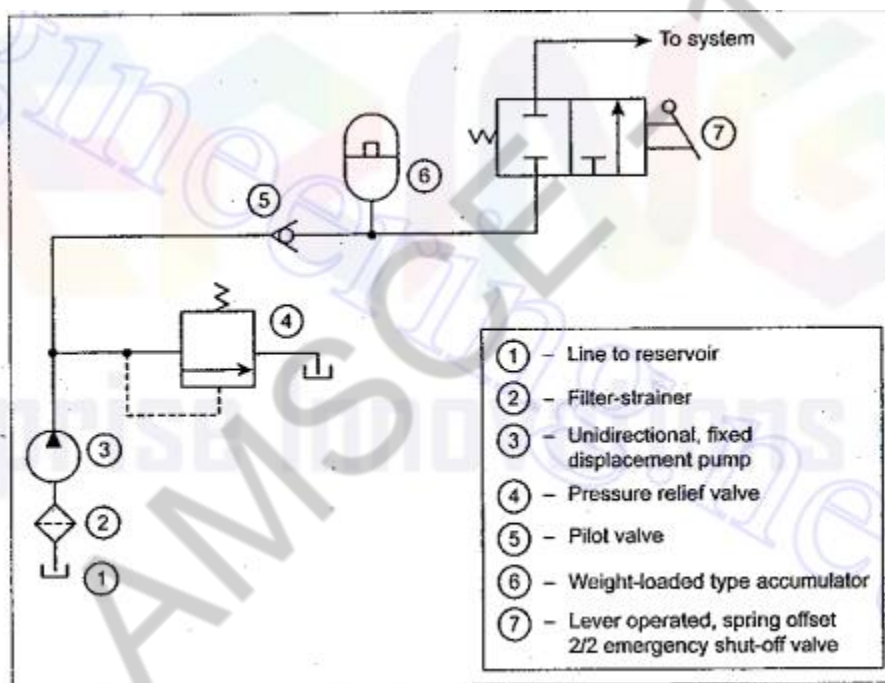

Fig. 8.11. Accumulator as a hydraulic shock absorber

6. Explain the air over oil intensifier with suitable example (Nov/Dec2006)

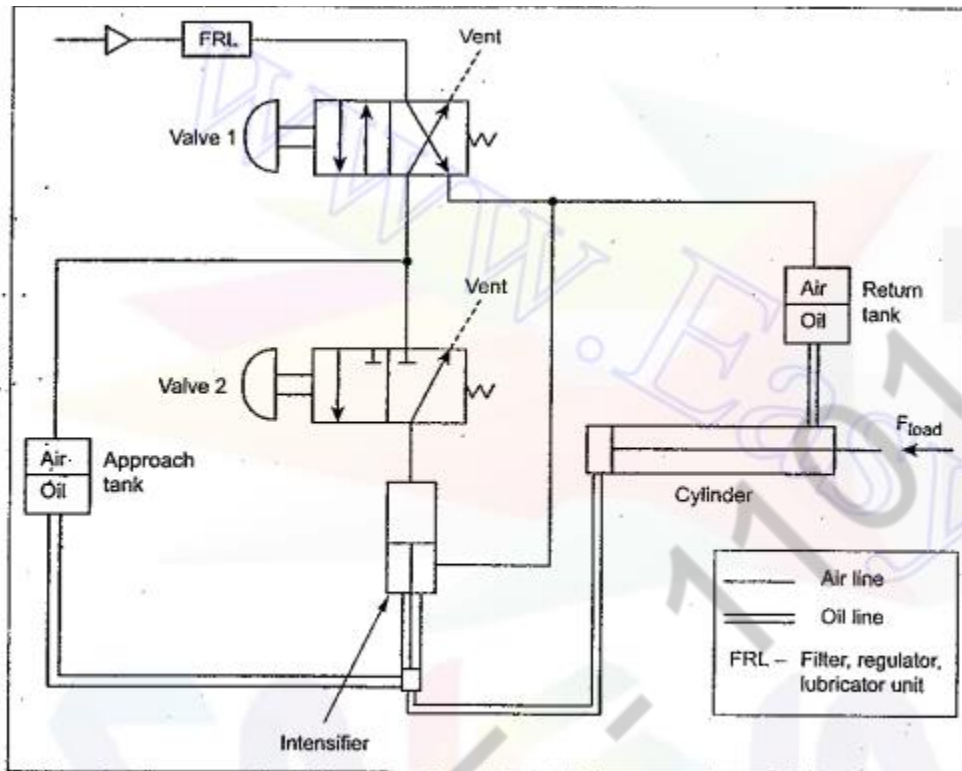

Fig. 8.18. Air-over-oil intensifier circuit

8.14.2. Air-Over-Oil Intensifier Circuit

- ✓ In some applications, the hydraulic and pneumatic circuits are coupled to best use of the advantages of both oil and air mediums.
- ✓ This combination circuit is also known as *hydro-pneumatic* or *pneumo-hydraulic circuits* or *dual pressure systems*.

8.14.2.1. Circuit

Fig.8.18 shows a typical air-over-oil intensifier. This circuit can be used for drawing a cylinder over a large distance at a low pressure and then over a small distance at high pressure (such as in punch press applications). This circuit consists two lines—air lines and oil lines. In the circuit, the air lines are shown by single lines and oil lines by double lines.

### 8.14.2.2. Operation

**Extension :** When the first 4/2 DC valve (valve 1) is shifted to left mode, the air from the reservoir flows to the approach tank. In the approach tank, the air forces the oil to the blind end of the cylinder through the bottom of the intensifier, as shown by double lines in Fig.8.18. Now the cylinder extends.

**Useful Work :** When the cylinder experiences its load, the second 4/2 DC valve (valve 2) is actuated to the left mode. This valve position sends air to the top end of the intensifier.

**Retraction :** When the valve 2 is released (shifted to right mode), the air flow from the reservoir is blocked. The air from the top end of the intensifier is vented to the atmosphere. This completes the high pressure portion of the cycle.

When valve 1 is released (*i.e.*, shifted to right mode), the air flow is diverted to return tank and also the air in the approach tank is vented. The diverted air flow pushes the oil to the rod end of the cylinder. This causes the cylinder to retract. The oil from the piston end of the cylinder is diverted back to the approach tank through the bottom end of the intensifier. This completes the entire cycle of operation.

## 7. With a neat sketch explain the weight loaded accumulator (Nov/Dec2006)

### 8.3.1. Construction

The construction and operation of a dead-weight type accumulator is illustrated in Fig.8.1. It consists of a piston rod or plunger loaded with a dead weight and moving within a cylinder to exert pressure on the hydraulic oil. The dead-weight provides the potential energy to compress the fluid. The dead-weight may be concrete block, iron or steel block, or any other heavy material. The piston should have a precision fit with the accumulator tube so as to reduce the leakage past the piston. One side of the accumulator cylinder is connected to the fluid source (pump) and the other side to the work load (machine).

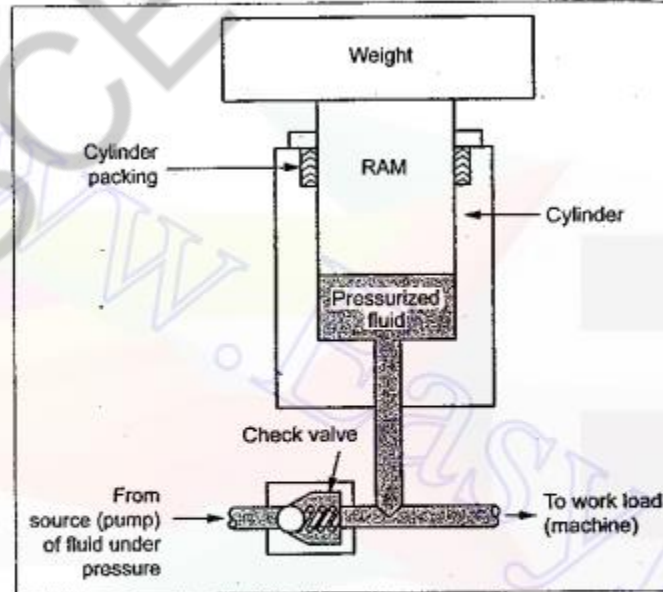

Fig. 8.1. Weight-loaded hydraulic accumulator

### 8.3.2. Operation

In the beginning, the ram is at the lower-most position. During idle periods of driven machine (say lift or crane) high pressure fluid (oil) supplied by the pump is admitted in the accumulator cylinder through the check valve. Fluid is allowed continuously till the ram reaches its uppermost position. At this position, the accumulator cylinder is full of fluid and the maximum amount of pressure energy is accumulated.

During the working stroke of the driven machine (*i.e.*, when it requires maximum amount of energy), the accumulated energy is discharged to the driven machine.

### 8.3.3. Advantages

The advantages of the weight-loaded type accumulators are :

1. The weight-loaded accumulators produce constant pressure for the full stroke *i.e.*, until all the fluid is sent out.
2. They can supply large volume of fluid under high pressure.
3. The large volume of fluid makes them possible to supply pressure to several hydraulic circuits.

## 8. Make a circuit showing an intensifier in a punching press application( April/May2008)

### 8.14.1. Intensifier Circuit in Punching Press Application

As we know, usually a heavy punching press requires two pumps (a low-pressure pump and a high-pressure pump) to obtain the high-pressure outlet flow required for the operation. But with the use of a pressure intensifier, one can eliminate the expensive high-pressure pump in the punching press application.

#### 8.14.1.1. Circuit

Fig.8.17 shows a basic hydraulic circuit employing an intensifier for use in a punching operation. This circuit consists of a low-pressure pump, 4/3 DC valve, pilot check valve, sequence valve, pressure intensifier, and cylinder. As shown in Fig.8.17, the intensifier should be installed closer to the cylinder to shorten the high-pressure lines.

#### 8.14.1.2. Operation

First operator places workpiece in fixture and shifts handle of 4/2 DC valve. When the 4/2 DC valve is shifted to the right side position, the oil flows to the blind end of the cylinder through the check valve. When the pressure in the cylinder reaches the sequence valve pressure setting, the sequence valve opens and supplies the flow to the intensifier. Now the intensifier starts to operate and gives high-pressure output. This high-pressure output of the intensifier closes the pilot check valve and pressurizes the blind end of the cylinder to perform the punching operation.

When the 4/2 DC valve is shifted to the left side position, the oil flows to the rod end of the cylinder. When it builds-up the pressure, the pilot signal opens the check valve. Thus the cylinder is retracted to the starting position.

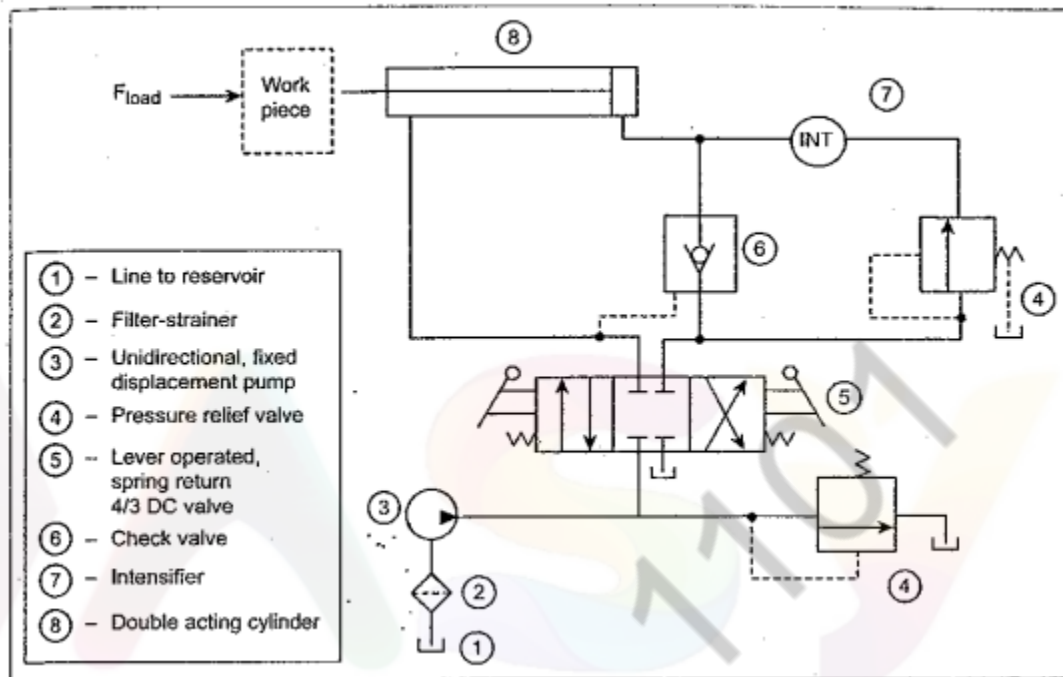

9. Write and explain the working principle of pressure intensifier with neat diagram (Nov/Dec2008)

#### 8.13.1. What are Pressure Intensifiers ?

- ✓ Pressure intensifiers, also known as *pressure boosters*, are used to compress the liquid in a hydraulic system to a value above the pump discharge pressure.
- ✓ In other words, a *hydraulic intensifier* is a device which converts a large-volume, low-pressure fluid supply into a proportionately small-volume, high-pressure fluid outlet.
- ✓ The intensifier is usually located in between the pump and the machine (e.g., press, crane, lift) that needs high pressure liquid for its operation.
- ✓ The action of the intensifier is similar to that of a *step-up electrical transformer*.
- ✓ It finds its application at places where a liquid of very high pressure is to be developed from available low pressure. Typical applications include hydraulic presses, riveting machines, and spot-welders.

As shown in Fig.8.16, the unit consists of two pistons—low pressure and high pressure—having a common piston rod. The larger, piston is exposed to pressure from a low-pressure pump. The low-pressure fluid (oil) is introduced to the larger piston side and thus it forces the piston to move. Neglecting losses due to friction, the smaller end of the piston exerts the same force on the fluid in the intensifier chamber or smaller cylinder.

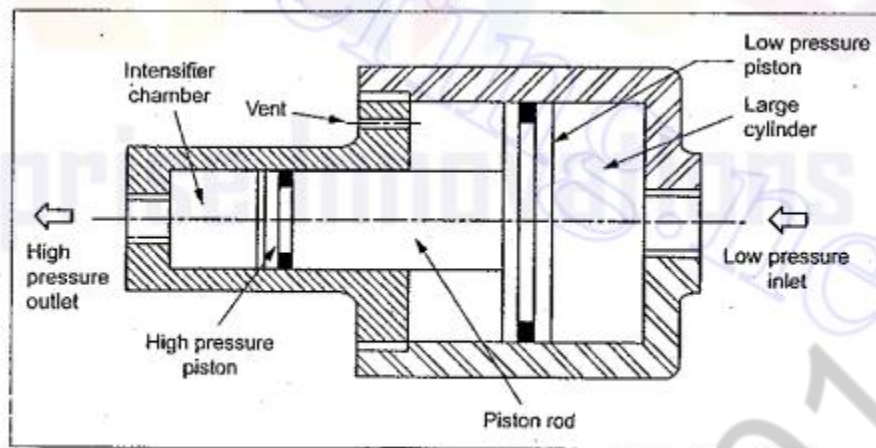

Fig. 8.16. Operation of a pressure intensifier

10 . Design and explain the working of regenerative circuits (May/June2009)

13.5. REGENERATIVE CIRCUIT

A regenerative circuit is used to speed up the extending speed of the double-acting cylinder.

13.5.1. Circuit

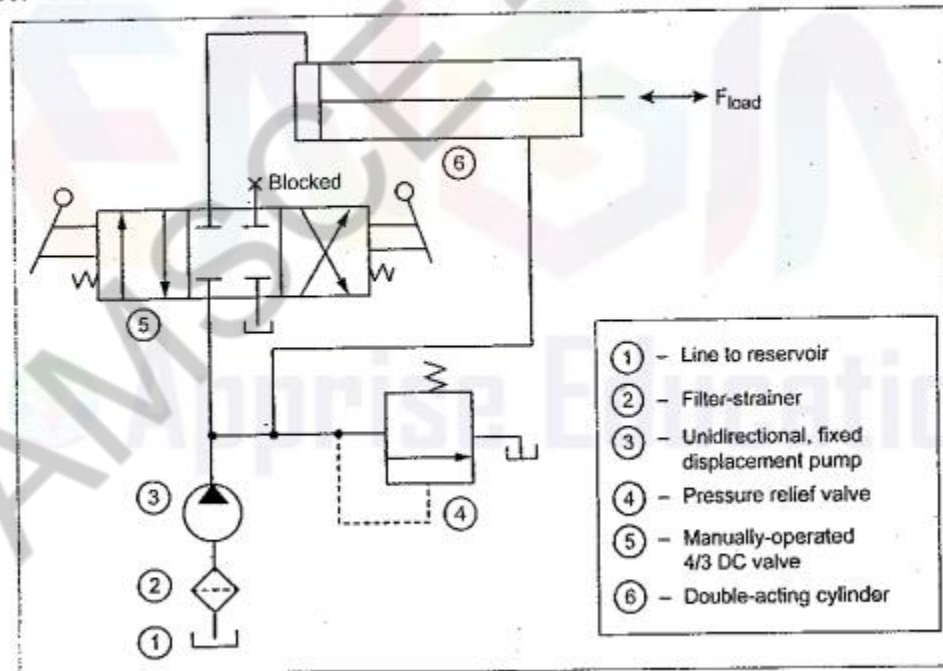

Fig. 13.3. Regenerative circuit

Fig.13.3 illustrates a regenerative circuit that can be used to speed up the extending speed of the double-acting cylinder. This circuit uses a manually-operated, three position, four way directional control valve (closed center position), and a double-acting cylinder. It should be noted in this circuit that the pipelines to the cylinder are connected in parallel and one of the ports of the DCV is blocked.

### 13.5.2. Operation

**Extension :** When the 4/3 DC valve is shifted to the left mode, the oil flows from the pump to the blind end of the cylinder. This pump flow extends the cylinder.

**Retraction :** When the 4/3 DC valve is shifted to the right mode, the oil from the pump bypasses the DC valve and enters into the rod end of the cylinder. Oil in the blank end drains back to the tank through the DC valve as the cylinder retracts.

11. Explain any two types of accumulator circuits with neat sketch (Apr/May 2010, May/june2012, April/May2015)

## 8.8. PISTON TYPE ACCUMULATOR

### 8.8.1. Construction

The construction and operation of a typical piston type accumulator is illustrated in Fig.8.4. It consists of a cylinder body and a moveable piston with proper seals.

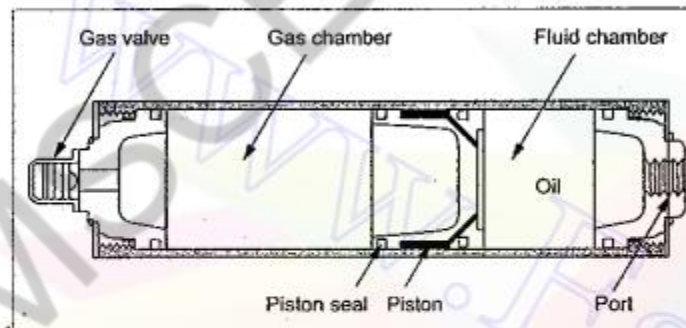

Fig. 8.4. Piston type accumulator

### 8.8.2. Operation

As shown in Fig.8.4, the piston serves as the barrier between the gas and oil. The gas is confined at the volume above the piston and the oil at the volume below the piston. The gas is compressed when the charged oil pushes the piston against it. This gas pressure is used as the potential energy to force the oil out when it is required in the circuit.

### 8.8.3. Advantage

The piston type accumulator has the ability to handle very high or low temperature system fluids.

## 8.4. SPRING-LOADED ACCUMULATORS

### 8.4.1. Construction

The spring-loaded accumulators are similar in construction to that of dead-weight type accumulators. In this type, instead of loading the ram with dead-weight, it is preloaded with compression spring, as shown in Fig.8.2. It consists of a cylinder body, a moveable piston, and a compression spring. The spring provides the compression energy required for this accumulator.

### 8.4.2. Operation

As the spring is compressed by the piston, the hydraulic fluid is forced into the accumulator cylinder. The pressure in the accumulator is dependent on the size and preloading of the spring. The accumulator pressure increases as the spring gets compressed, because incoming fluid flow increases the load required to compress the spring.

When the fluid is discharged out of the accumulator, it causes the spring to expand. As the spring approaches its free length, the accumulator pressure drops to a minimum. Thus the pressure exerted by the spring-loaded type accumulator on the fluid is not constant as in the dead-weight type.

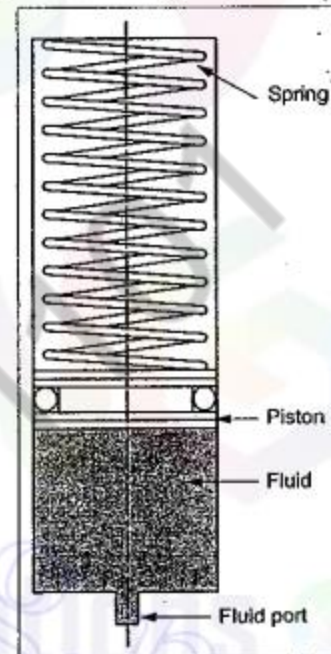

Fig. 8.2. Spring-loaded type accumulator

### 8.4.3. Advantages

1. The spring-loaded accumulators are usually smaller and less expensive than the dead-weight type accumulators.
2. They are easy to maintain.

## 8.10. BLADDER TYPE ACCUMULATORS

### 8.10.1. Construction

The construction of a typical bladder type accumulator is depicted in Fig.8.6. It consists of a bag or bladder of synthetic material which is precharged with gas to a determined pressure. This bladder is placed within the accumulator shell and the balance of the space filled with oil. Thus the bladder serves as an elastic barrier between the gas and oil.



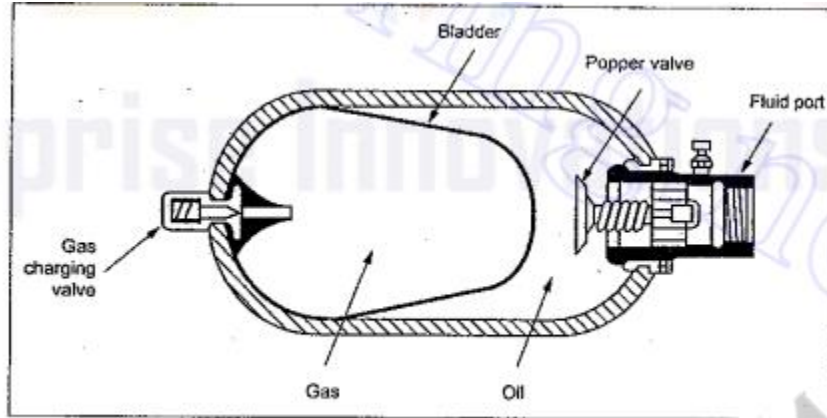

Fig. 8.6. Bladder-type gas-loaded hydraulic accumulator

12. Explain the following circuits with neat sketch. April/May 2012

i) Meter-In ii) Meter Out circuits

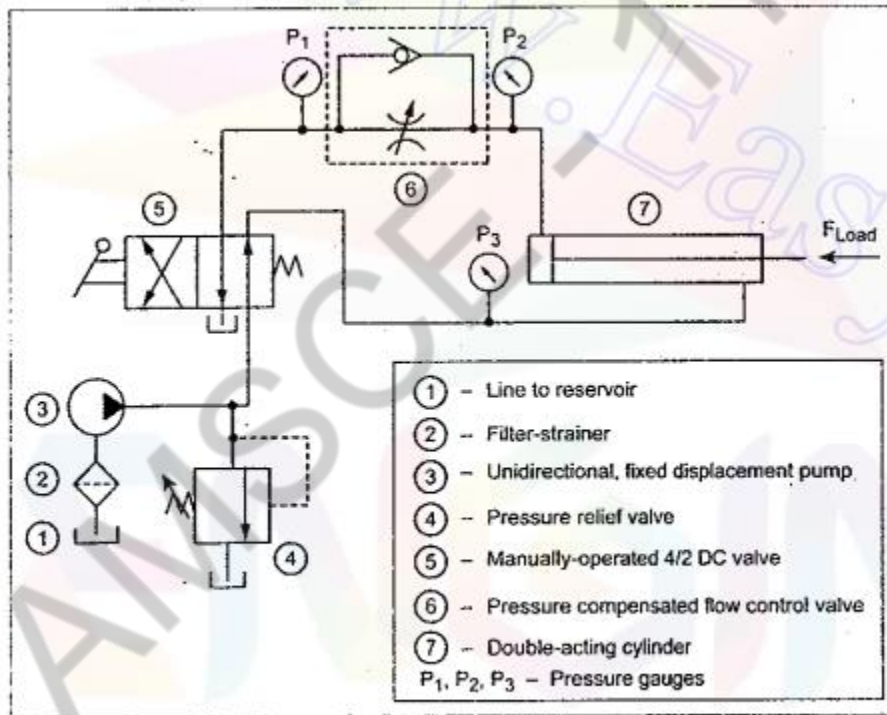

Fig. 13.8. Meter-in speed control of hydraulic cylinder using flow control

### 13.11.2.2. Operation

**Extension :** When the 4/2 DC valve is mechanically shifted to its left mode, oil flows from the pump to the blind end of the cylinder via the flow control valve. This pump flow extends the cylinder. Here it can be noted that the extending speed of the cylinder depends on the setting of the flow control valve. Thus the extending speed of the cylinder can be increased or decreased just by regulating the flow of fluid in the flow control valve.

**Retraction :** When the 4/2 DC valve is shifted to its right mode, oil flows from the pump to the rod end of the cylinder and hence the cylinder retracts. The oil from the blind end of the cylinder drains back to the oil tank through the check valve as well as the flow control valve.

### ii) Meter out circuit

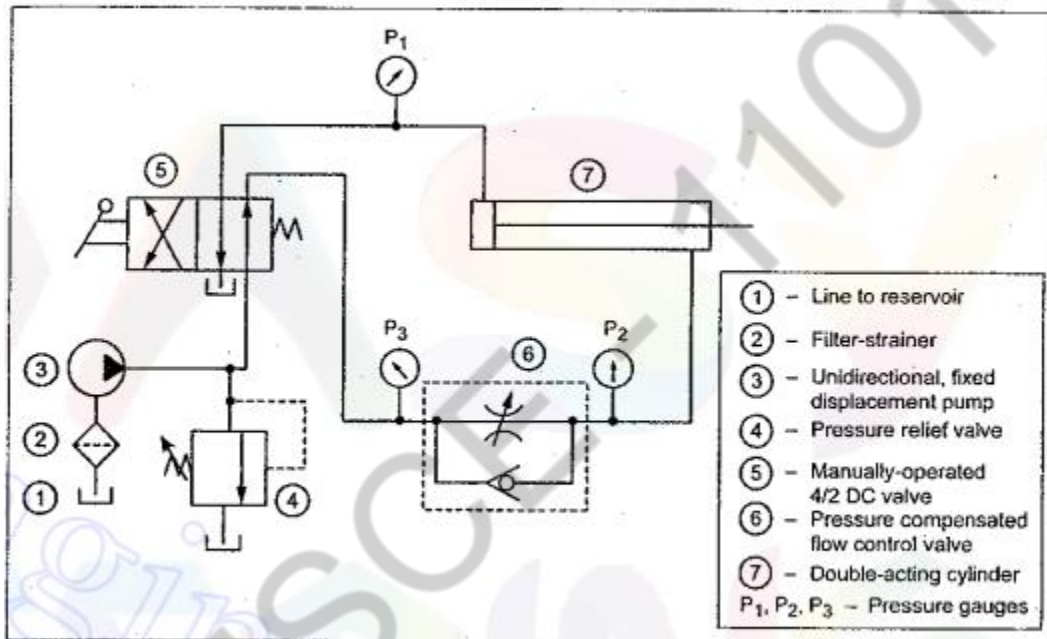

Fig. 13.9. Meter-out speed control of hydraulic cylinder using flow control

### 13.11.3.2. Operation

The operation meter-out circuit is very much similar to that of the meter-in circuit. The only difference is that meter-out flow control system controls the oil flow rate out of the cylinder. In other words, meter-out circuit controls the retracting speed of the cylinder.

## UNIT –IV PART-A

### PNEUMATIC SYSTEMS AND COMPONENTS

#### **1. Under what conditions pneumatic systems are preferred?( Nov/Dec2012 )**

Pneumatics is study of mechanical motion caused by pressurized gases and how this motion can be used to perform engineering tasks. Pneumatics is used mainly in mining and general construction works. Pneumatic devices are used frequently in the dentistry industry across the world. On the other hand, hydraulics means use of pressurized fluids to execute a mechanical task. Hydraulics is frequently used in the concepts of turbines, dams, and rivers. Air brakes in buses, air compressors, compressed air engines, jackhammers, and vacuum pumps are some of the most commonly used types of mechanical equipment that are based on pneumatics technology. Commonly seen hydraulics based equipment types are hydraulic presses, hydraulic hoppers, hydraulic cylinders, and hydraulic rams. In the subsequent sections of this article, you will learn how a pneumatic system works, what its best features are, and its major advantages over hydraulic systems.

#### **3. Name the different types of cylinder mountings.( Nov/Dec 2012)**

**Flange mounting:** The flange can be attached to the head (item a) or to the base (b). In a position B, the fastening screws must absorb the force from the piston, in a position A, on the other hand only the withdrawal force.

**Foot mounting:** Here the fastening screws are subjected to shear (e, f). In e there is also a turning moment.

**Mounting on end joint:** Gives the cylinder freedom of movement in one (g) or in all planes (h). The centre of gravity is always at the end of the cylinder.

#### **Trunnion mounting**

Can be attached at any point along the length of the cylinder (i, k). A common design is pivoting at the centre of gravity of the cylinder.

**4. What is the function of air Filter and Dryer? (Nov/Dec 2012)**

i) The function of an air filter is to remove contaminants from air before it reaches the pneumatic components such as valves and actuators.

ii) The purpose of the dryer is to reduce the relative humidity and dew point of the compressed air from the compressor.

**5. When to use timer and relay? Why? (Nov/Dec2012)**

Their purpose is to control an event based on time. The difference between relays and time delay relays is when the output contacts open & close: on a control relay, it happens when voltage is applied and removed from the coil on time delay relays, the contacts can open or close before or after some time delay.

**6. What do you mean by logic control? (May/June2013)**

The logic control is a control based on logic functions like AND, OR, NOT etc. The components of logic control are sensors and switching elements called binary elements, i.e. at any moment they can be in one of the two states. "ON-OFF".

**7. What is a Ladder diagram? (May/June2013, 2014,) (April/May2015)**

The ladder diagram is a representation of hardware connections between switches, relays and solenoids etc., which constitute the basic components of an electrical control system. The left leg of the ladder connected to the power and the right to the ground.

**8. What is the function of quick exhaust valve? (May/June 2014)**

One quick exhaust valve is used in each port of the cylinder to ensure an increase in the speed of the rod in both directions. The use of a quick exhaust valve in a pneumatic system helps to increase cycling speed, in turn, that ensures a much smaller valve to be effectively used for the process.

**9. What are fluidic devices? (May/June2014)**

The term fluidics is normally used when devices have no moving parts, so ordinary hydraulic components such as hydraulic cylinders and spool valves are not considered or referred to as fluidic devices. A jet of fluid can be deflected by a weaker jet striking it at the side.

**10. State any four advantages of Pneumo-hydraulic circuits. (May/June2012)**

Over pneumatics, hydraulics is capable of moving heavier loads and having greater force, and since its working fluids are incompressible, it Pneumatic Drill have minimum spring actions. But at the same time pneumatics are cleaner, the system uses no return lines and gases are exhausted to the atmosphere.

**11. What is the function of pressure regulator in a pneumatic system? (April/May2015)**

The primary purpose of pressure regulators is to control pressure with close tolerances to ensure that compressed air in a pneumatic system is not wasted. Pressure regulating valves accomplish this by maintaining constant output pressure under various input pressures and output flows

**12. What is fluidics? (April/May 2015)**

Fluidics, *or* fluidic logic, is the use of a fluid to perform analog or digital operations similar to those performed with electronics. The physical basis of fluidics is pneumatics and hydraulics, based on the theoretical foundation of fluid dynamics.

Fluidics is the technology that utilizes fluid flow phenomena in components and circuits to perform a wide variety of control functions including sensing, logic and m more functions.

**13. Define FRL unit? (Nov/Dec2011)**

Air is not clean and hence contamination may result in pneumatic circuit. Also, due to time fluctuations, the receiver air pressure does not remain constant. Also, some parts of the Pneumatic system have to be lubricated for proper maintenance. For cleaning the air, regulating the pressure of air and lubricating pneumatic parts, three units 'Filter - Pressure Regulator - Lubricator' (Trio unit) are put together and this combined unit - Trio unit - is called FRL unit.

**14. What is the purpose of Shuttle valve in pneumatic circuit? (Nov/Dec2011)**

A shuttle valve is a type of valve which allows fluid to flow through it from one of two sources. Generally a shuttle valve is used in pneumatic systems, although sometimes it will be found in hydraulic systems

**15. What is a fast exhaust valve? (April/May 2012)**

A fast exhaust valve is used to vent cylinder quickly. It is primary used with spring return (single acting) pneumatic cylinders.

**16. How can you specify an air compressor? (April/May2008)**

Making the right choice of product, and supplier, will depend first and foremost on the actual application's needs for a compressed air supply. That requirement has to be quantified in terms of compressor size, flow, pressure, air quality and usage patterns. These variables then need to be matched to the available types of compressor technology and their relative performance in terms of output, energy-efficiency and Total Cost of Ownership.

**17. What are the functions of FRL unit? (Nov/Dec 2009)**

Like pressure regulators, the lubricator function of an FRL unit ensures that the air is dosed with a small amount of lubrication oil to help pneumatic components work effectively. Lubricators ensure that the correct amount of oil is being used to reduce the friction between moving components.

**18. What are the basic components of pneumatic system? (Nov/Dec 2009)**

The main components of the compressed air production, transportation, and distribution system consist of air compressor, electric motor and motor control centre, pressure switch, check valve, storage tank, pressure gauge, auto drain, air dryer, filters, air lubricator, pipelines, and different types of valves.

**19. Sketch the pneumatic symbol of pneumatic regulator (April/May2010)**

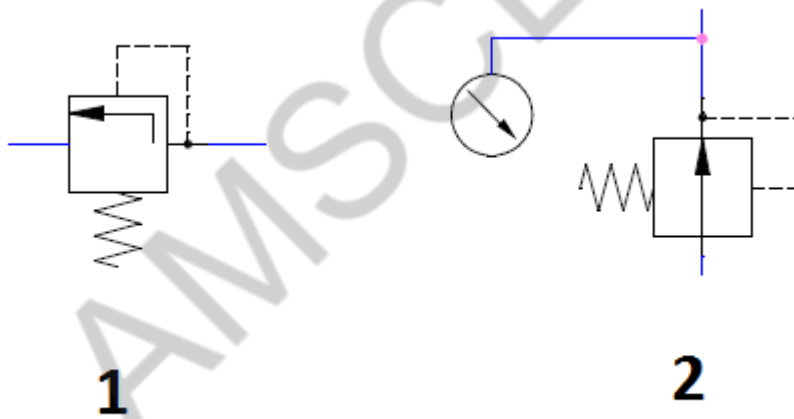

**20. List the components associated with PLC system (April/May2010)**

Programmable Logic Controllers (PLC) has three components. These three PLC components are: processor, power supply, and an input/output (I/O) section. The processor, or the brain of the PLC system, is a solid-state device designed to perform a wide variety of production, machine tool, and process-control functions.

**21. Draw any one type of synchronizing circuit (April/May2010)**

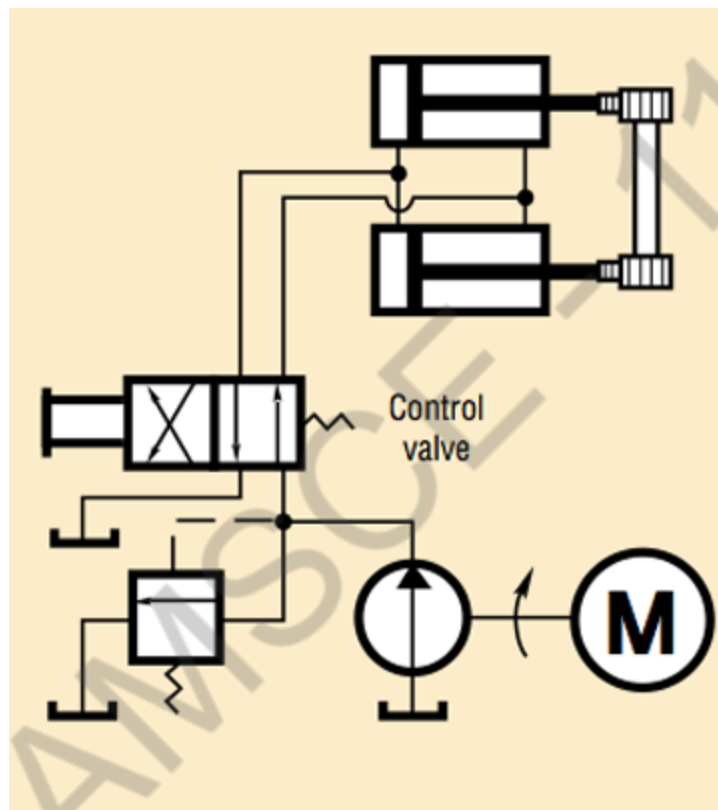



## UNIT-IV

### PART-B

#### 1. Describe various pneumatic actuator with neat sketch (Nov/Dec2005)

##### 12.10. PNEUMATIC LINEAR ACTUATORS (PNEUMATIC CYLINDERS)

###### 12.10.1. What are Pneumatic Cylinders ?

- ✓ *Pneumatic cylinders are the devices for converting the air pressure into linear mechanical force and motion.*
- ✓ The pneumatic cylinders are basically used for single-purpose applications such as clamping, stamping, transferring, branching, allocating, ejecting, metering, tilting, bending, turning and many other applications.

Sl.No.	Cylinder Type	Diagram	Description
1.	Single-acting cylinder		Air pushes the piston in one direction and the piston is returned by means of an external spring.
2.	Double-acting cylinder		The force exerted by the compressed air moves the piston in both directions.
3.	Cushion end cylinder		Cushioning is used in the end positions, to prevent sudden damaging impacts.
4.	Tandem cylinder		Here two cylinders are arranged in series so that the force obtained from the cylinder is almost doubled.
5.	Dual linear cylinder (Three position cylinder)		Similar to tandem cylinder, but the piston and rod assemblies of a dual actuator are not fastened together as in the tandem cylinder.
6.	Double-rod cylinder (Through rod cylinder)		It has piston rods extending from both ends of the cylinder. It produces equal force and speed on both sides of the cylinder.
7.	Telescoping cylinder		It is a two-stage, double-acting telescopic cylinder; for more details refer Section 6.6.2.

2. Develop an electro pneumatic circuit for the following sequence  $A^+B^+A^-B^-$  where A and B stands for cylinders +indicate extension and – indicate retraction of cylinders (Nov/Dec2005)

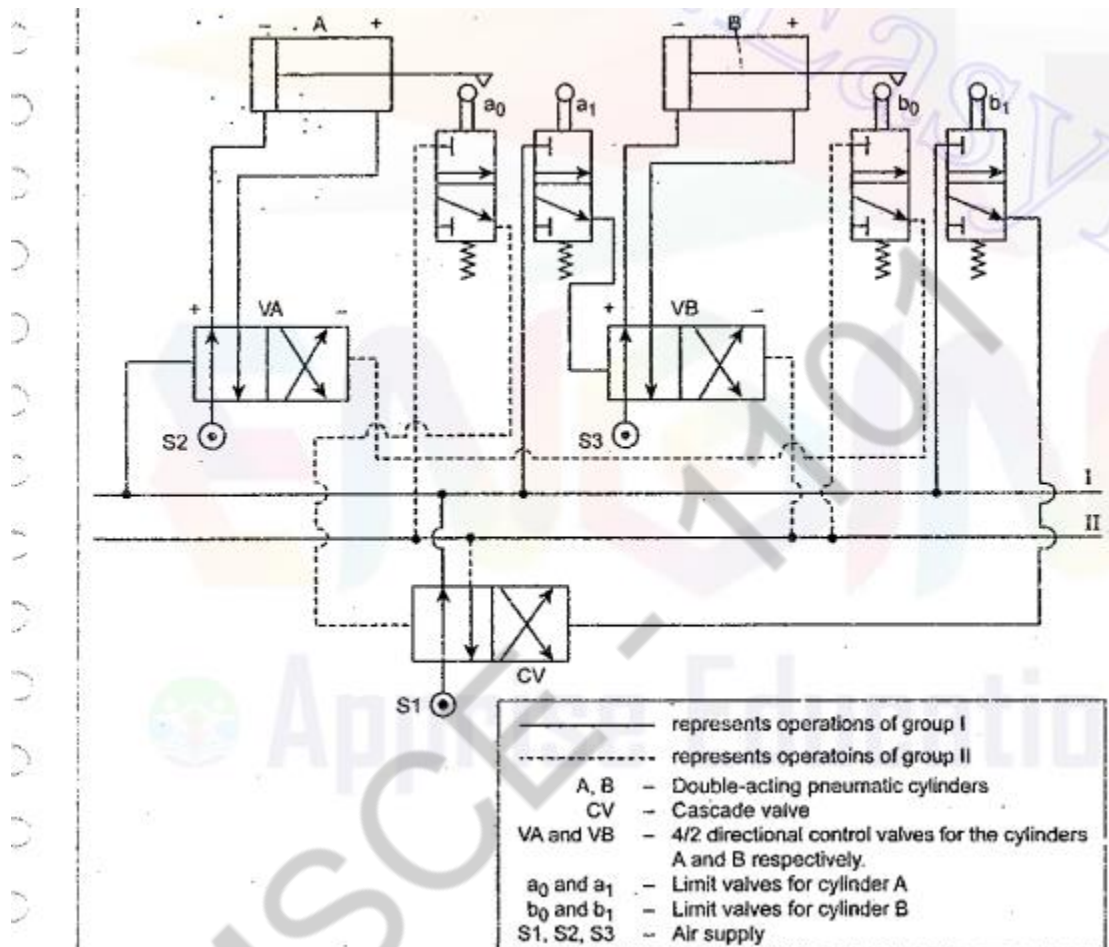

☺ **Solution :** The solution to this design problem is very much similar to that of the previous problem. So the same procedure may also be followed for this problem.

**Step 1 :** Given sequence :  $A^+ B^+ B^- A^-$

**Step 2 :** Grouping :  $\frac{A^+ B^+}{I}, \frac{B^- A^-}{II}$

**Step 3 :** Number of pressure lines = Number of groups = 2

**Step 4 :** (i) Number of pilot operated 4/2 DC valve = Number of cylinders = 2

(ii) Number of limit valves = 2 × Number of cylinders = 2 × 2 = 4

(iii) Number of cascade valves = Number of groups – 1 = 2 – 1 = 1

**Step 5 :** The cascade circuit and their valve connections for the sequence  $A^+ B^+ B^- A^-$  is drawn as shown in Fig.13.23.

3. Develop an electro hydraulic circuit for the following sequence  $A^+B^+B^-A^-$  where A and B stands for cylinders +indicate extension and – indicate retraction of cylinders (Nov/Dec2005) (Nov/Dec2008)

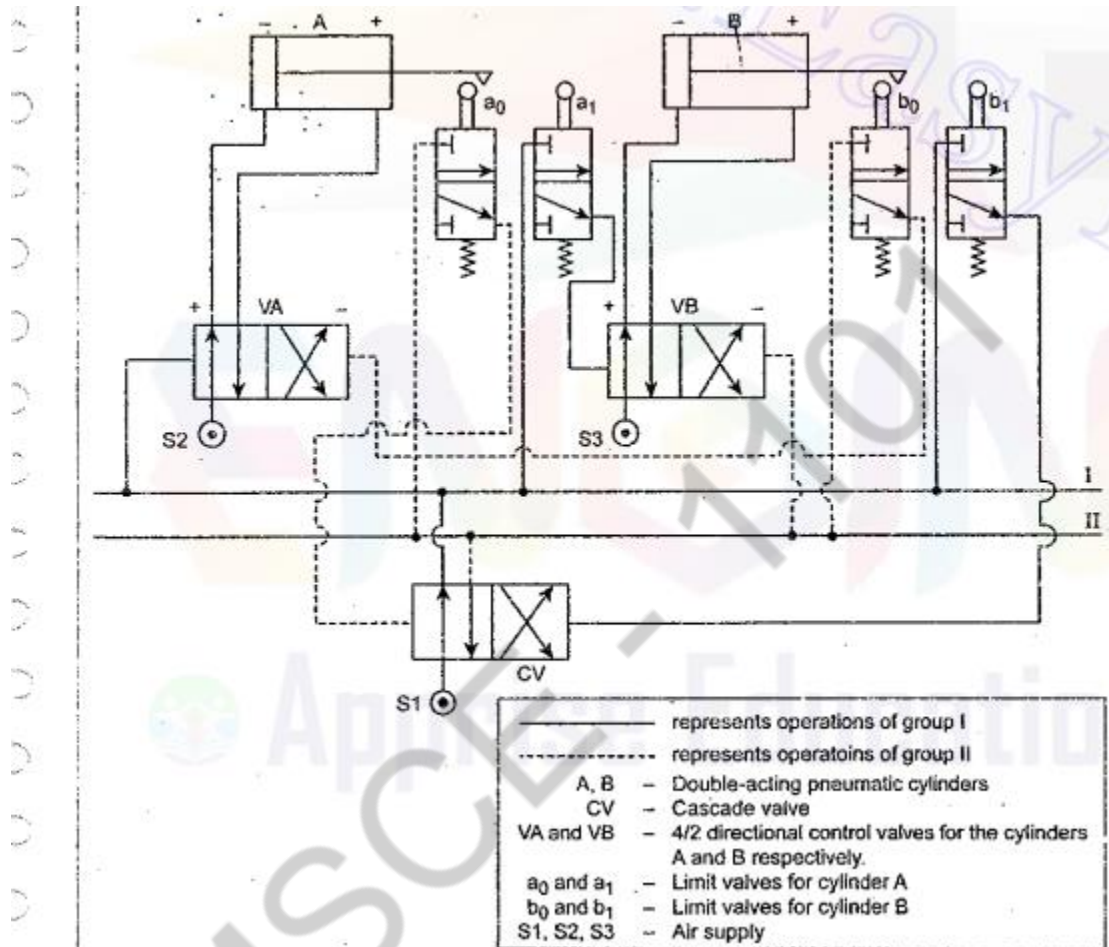

☺ **Solution :** The solution to this design problem is very much similar to that of the previous problem. So the same procedure may also be followed for this problem.

**Step 1 :** Given sequence :  $A^+ B^+ B^- A^-$

**Step 2 :** Grouping :  $\frac{A^+ B^+}{I}, \frac{B^- A^-}{II}$

**Step 3 :** Number of pressure lines = Number of groups = 2

**Step 4 :** (i) Number of pilot operated 4/2 DC valve = Number of cylinders = 2

(ii) Number of limit valves = 2 × Number of cylinders = 2 × 2 = 4

(iii) Number of cascade valves = Number of groups – 1 = 2 – 1 = 1

**Step 5 :** The cascade circuit and their valve connections for the sequence  $A^+ B^+ B^- A^-$  is drawn as shown in Fig.13.23.

#### 4. D) What are advantages of PLC? (April/May2005)

The PLCs replace electromechanical relays due to their following advantages :

1. PLCs are more reliable and faster in operation.
2. They are smaller in size and can be more readily expanded.
3. They require less electrical power.
4. They are less expensive when compared to electromechanical relays for the same number of control functions.
5. Hard-wired electromechanical relays lack flexibility. For instance, when system operation requirements change, then the relays have to be rewired.
6. PLCs have very few hardware failure when compared to electro-mechanical relays.
7. Special functions such as time-delay actions and counters, can be easily performed using PLCs.

#### ii) Explain the working principle of PLC with a neat block diagram (April/May2005)

##### 15.8.1. Introduction

Programmable logic controller (PLC) is one of the important micro-processor based controller. As we aware, microprocessor has a tremendous impact on industrial control and instrumentation due to its high reliability and flexibility at the design and implementation stages. The decreasing cost of microprocessors with increasing facilities in them are acting as catalyst in their widening scope of applications. In recent years, PLCs are being used in place of electro-mechanical relays or cam-operated logic controllers to control fluid power systems.

##### 15.8.2. What is a Programmable Logic Controller (PLC) ?

- ✓ *Definition : A programmable logic controller (PLC) can be defined as a digital electronic device that uses a programmable memory to store instructions and to implement functions such as logic, sequencing, timing, counting, and arithmetic in order to control machines and processes.*
- ✓ In simple terms, a PLC is a user-friendly electronic computer designed to perform logic functions such as AND, OR, and NOT for controlling the operation of industrial equipment and processes.
- ✓ Thus a PLC consists of solid-state digital logic elements for making logic decisions and providing corresponding outputs.
- ✓ Basically, PLCs are designed as a replacement for hard-wired electro-mechanical relays to control fluid power systems.

#### 15.9. MAJOR UNITS OF A PLC

A PLC consists of the three major elements, as shown in Fig.15.17. They are :

1. Central processing unit (CPU),
2. Programmer/monitor (PM), and
3. Input/output module (I/O).

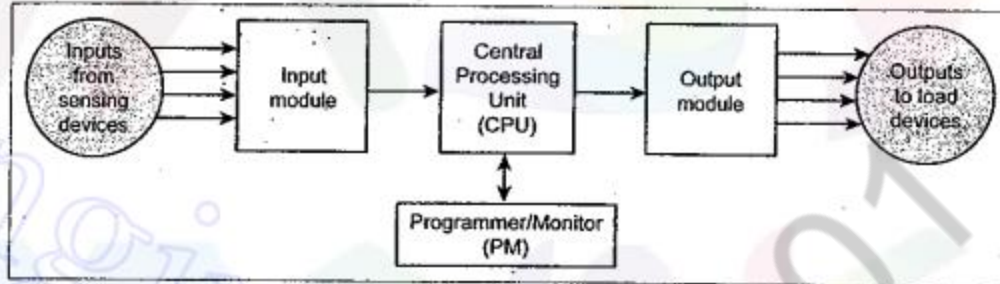

Fig. 15.17. Block diagram of a PLC

iii) How does a PLC differ from Microprocessor? (April/May2005)

PLCs are similar to general-purpose computers. But PLCs have certain features which are specific to their use as controllers. Some of the important features of PLCs are :

1. PLCs are rugged and designed to withstand vibrations, temperature, humidity, and noise.
2. The interfacing for inputs and outputs is inside the controller.
3. They are easily programmed and have an easily understood programming language. Programming is primarily concerned with logic and switching operations.

5. Explain with block diagram the components present in a PLC and give their functions (May/June2006)

#### 15.9. MAJOR UNITS OF A PLC

A PLC consists of the three major elements, as shown in Fig.15.17. They are :

1. Central processing unit (CPU),
2. Programmer/monitor (PM), and
3. Input/output module (I/O).

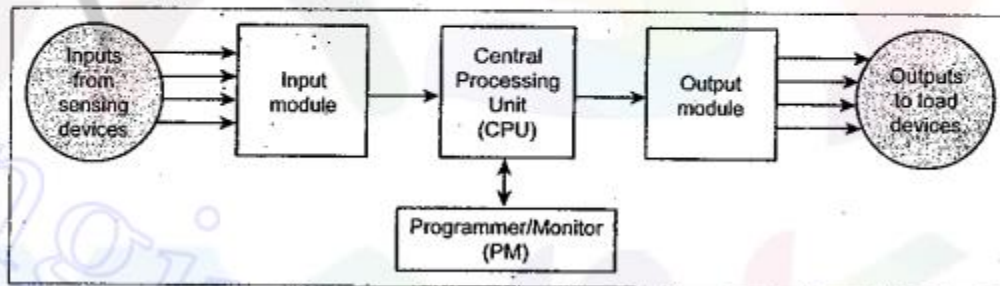

Fig. 15.17. Block diagram of a PLC

### 15.9.1. Central Processing Unit (CPU)

- ✓ The CPU controls and processes all the operations within the PLC, that's why this unit is referred as the 'brain' of the PLC.
- ✓ **Function :** The CPU (i) receives input data from various sensing devices such as switches, (ii) executes the stored program, and (iii) delivers corresponding output signals to various load control devices such as relay coils and solenoids.
- ✓ It consists a microprocessor with a fixed memory (ROM-'read only memory') and a variable memory (RAM-'random access memory').

### 15.9.2. Programmer/Monitor (PM)

- ✓ The programmer/monitor unit allows the user to enter the desired programme into the RAM.
- ✓ The programme which is entered in relay logic (in RAM) determines the sequence of operation of the system to be controlled.

### 15.9.3. Input/Output Module (I/O)

- ✓ This module interfaces between the fluid power system input sensing and output load devices and the CPU.
- ✓ **Function :** The purpose of the I/O module is to transform the various signals received from or sent to the fluid power interface devices (such as push-button switches, pressure switches, limit switches, solenoid coils, motor relay coils, and indicator lights).

ii) What is cascade control? Explain giving suitable example circuit. (May/June2006)  
(Ref.Q.No.2,3)

### 13.26.1. Cascade Method of Pneumatic Circuit Design

The cascade method is found to be the simplest and easiest method of designing pneumatic logic circuits.

#### 13.26.1.1. Procedure

The following step by step procedure may be followed while using the cascade method.

- Step1 : Each cylinders are given, for convenience, individual letters (say A, B, C, etc.). The given sequence is written first with '+' representing extension (forward) stroke of the cylinder and '-' representing retraction (return) stroke of the cylinder. (For example A<sup>+</sup>, B<sup>+</sup>, A<sup>-</sup>, B<sup>-</sup>, etc.)

**Step 2 :** The given sequence is split into minimum number of groups. The grouping can be done as below :

- (i) The first group is split where the change in stroke occurs.
- (ii) The second, third and subsequent groups are formed such that maximum of one change occurs within the group.
- (iii) No letter should be repeated within any group.
- (iv) The groups are identified by letters like I, II, III, etc.

**Illustration :** Let us assume the sequence  $A^+ B^+ B^- C^+ C^- A^-$ . This sequence can be splitted into three groups as shown below :

$$\frac{A^+ B^+}{I}, \frac{B^- C^+}{II}, \frac{C^- A^-}{III}$$

**Step 3 :** Each group is assigned a pressure manifold line which must be pressurised only during the time the particular group is active.

$$\therefore \text{Number of pressure lines} = \text{Number of groups}$$

**Step 4 : Selection of valves :**

- (i) Each cylinder is provided with a pilot operated 4/2 DC valve.

$$\therefore \text{Number of pilot control valves} = \text{Number of cylinders}$$

- (ii) Limit valves are positioned at either end actuated by the piston rod to identify the extension and retraction of cylinders. The limit valves are denoted by  $a_0, a_1, b_0, b_1$ , etc., where the suffix '0' corresponds to valves which are actuated at the end of return stroke and the suffix '1' corresponds to valves which are actuated at the end of forward stroke. Each cylinder requires two limit valves.

$$\therefore \text{Number of limit valves} = 2 \times \text{Number of cylinders}$$

Each manifold line supplies air pressure to those limit valves within its particular group.

- (iii) In order to pressurize the various manifold lines in the proper order, one or more group changing valves or cascade valves are used.

**Step 5 :** The valve connections are made as follows :

- (i) The output of each limit valve is connected to the pilot input corresponding to the next sequence step.
- (ii) The limit valve corresponding to the last step of the given group is 'not' connected to the pilot actuation of the DC valve of next cylinder. Instead, it is connected to the pilot line of the group changing or cascade valve so as to pressurize the manifold of the subsequent group.

This manifold line is then connected to the pilot line corresponding to the first step of the next group.

6. I) Describe the operation of FRL unit (Nov/Dec2006)

11.9.5. FRL Unit

- ✓ In most pneumatic systems, the compressed air is first filtered and then regulated to the specific pressure and made to pass through a lubricator for lubricating the oil. Thus usually a filter, regulator, and lubricator are placed in the inlet line to each air circuit. These may be installed as separate units, but more often they are used in the form of a combined unit.
- ✓ The combination of filter, regular, and lubricator is often labelled as *FRL unit* or *service unit*.
- ✓ Fig.11.11 illustrates the arrangement of a FRL unit.

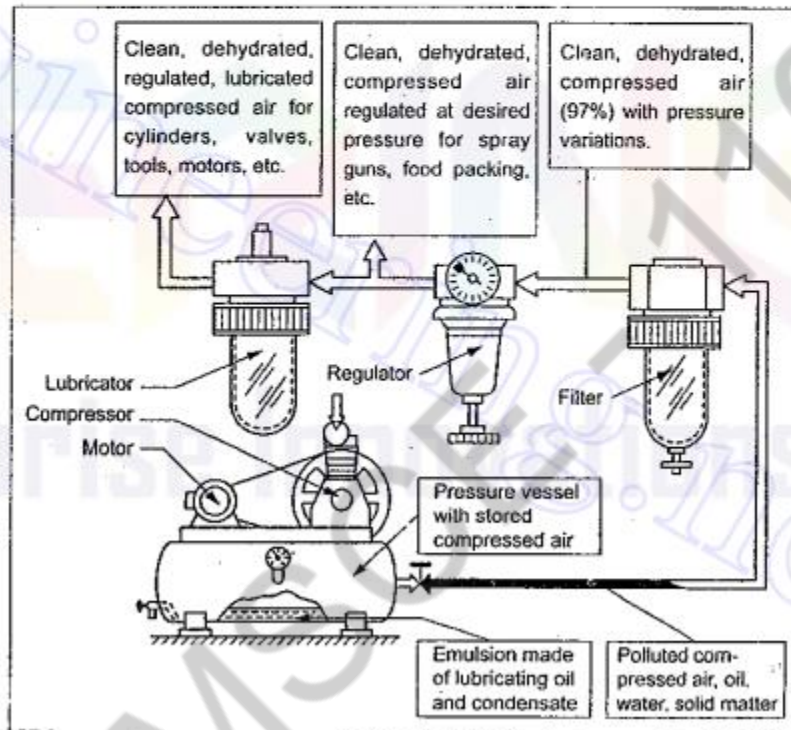

- ✓ **Composite symbol** : Fig.11.12 illustrates how individual component symbols form a composite symbol of a FRL unit.

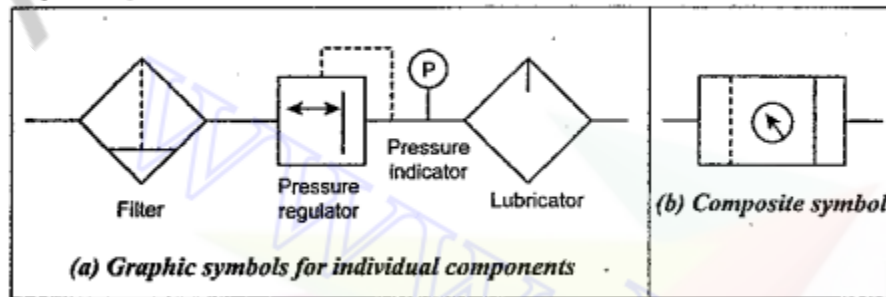

Fig. 11.12. FRL unit graphic symbol



ii) All the types of actuators used in pneumatics (Nov/Dec2006) (Ref. Q.No.1)

iii) Quick exhaust valve and silencer (Nov/Dec2006)

## 11.10. MUFFLERS (OR PNEUMATIC SILENCERS)

### 11.10.1. What are Mufflers ?

- ✓ **Function :** The function of muffler (also known as pneumatic exhaust silencer) is to control the noise caused by a rapidly exhausting air-stream flowing into the atmosphere.
- ✓ Noise created by air exhausting from an air system not only cause nervous tension and dissatisfaction among the operators, but also results in mental fatigue, lack of concentration, and inefficiency. This exhaust noises can be greatly reduced by installing a muffler at each pneumatic exhaust port.

### 11.10.2. Construction and Operation

The construction and operation of a typical pneumatic silencer is illustrated in Fig.11.13(a).

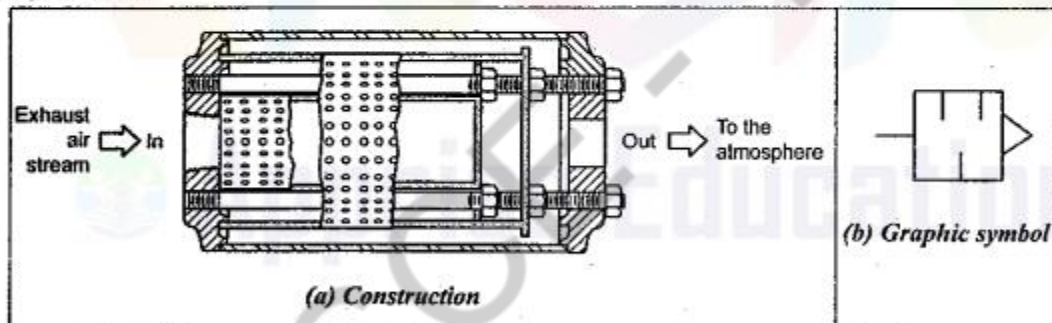

Fig. 11.13. Muffler

As shown in Fig.11.13 (a), the exhaust air stream enters one end, and passes out the another end after passing through a series of baffles. The baffle tubes are perforated with a large number of small holes. The outer shell acts as a barrier and helps guide the stream toward the exit to the atmosphere.

## 12.6. QUICK EXHAUST VALVE

### 12.6.1. What is a Quick Exhaust Valve ?

- ✓ A quick exhaust valve is a typical shuttle valve. *The quick (or fast) exhaust valve is used to exhaust the cylinder air to the atmosphere quickly.*
- ✓ It is basically used with spring return single-acting pneumatic cylinders to increase the piston speed of cylinders.
- ✓ The higher speed of piston in a cylinder is possible by reducing the resistance to flow of the exhausting air during motion of the cylinder. The resistance can be reduced by expelling the exhausting air to the atmosphere quickly by using a special valve. That's why this valve is known as a quick exhaust valve.

### 12.6.2. Construction and Operation

The construction and operation of a typical quick exhaust valve is shown in Fig.12.6. It consists of a movable disc and three ports—an inlet port (P), and exhaust port (R), and a cylinder port (A). Its working principle is very much similar to that of a shuttle valve.

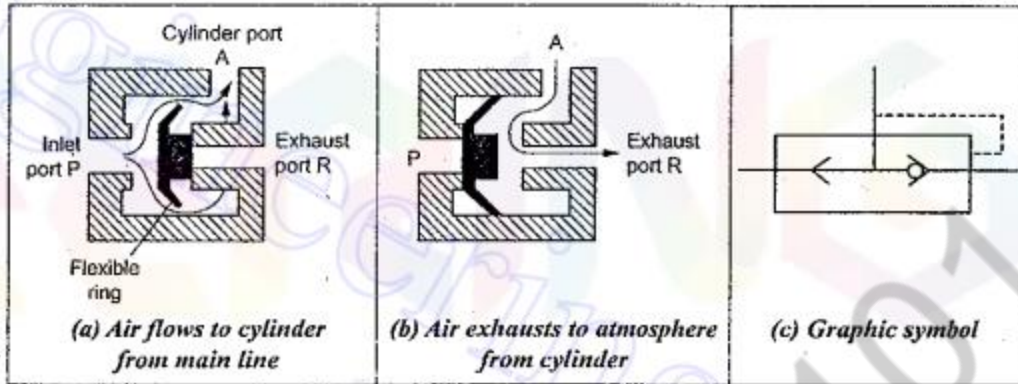

Fig. 12.6. Quick exhaust valve

When the air flowing to the cylinder from the DC valve is applied at port P, then the flexible ring covers the exhaust port R, whereby the compressed air passes from port P to the cylinder through port A (Fig.12.6(a)).

But the return air from the cylinder pushes the flexible ring to cover the inlet port P, whereby the exhaust air immediately expelled to the atmosphere (Fig.12.6(b)). Thus the resistance to piston movement is reduced considerably and the speed of the piston in the cylinder is accelerated proportionately.

## 7. Discuss the working principle of an air compressor (Nov/Dec2007)

### 11.3. PISTON-TYPE RECIPROCATING COMPRESSOR

- ✓ Piston compressors are the most commonly used compressors in the fluid power industry.
- ✓ The construction and working of a piston-type reciprocating compressor is very much similar to that of an internal combustion (IC) engine.

#### 11.3.1. Construction

A typical piston-type reciprocating compressor consists of a cylinder, cylinder head, piston with piston rings, inlet and outlet valves, connecting rod, crank, crankshaft, bearings, etc. The arrangement of a basic single cylinder compressor is illustrated in Fig.11.2.

**Inlet stroke :** During the downward motion of the piston [Fig.11.2(a)], the pressure inside the cylinder falls below the atmospheric pressure and the inlet valve is opened due to the pressure difference. The air is drawn into the cylinder until the piston reaches the bottom of the stroke.

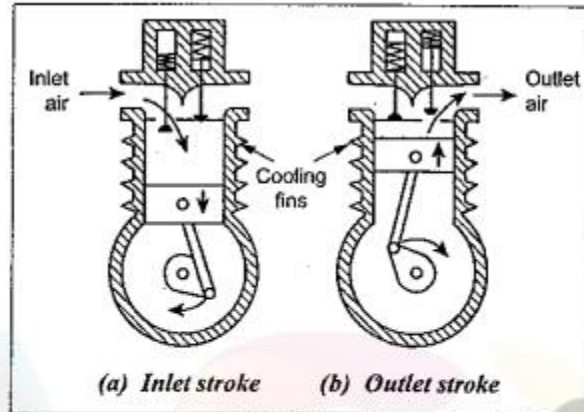

*Fig. 11.2. Single cylinder compressor*

**Outlet stroke :** As the piston starts moving upwards [Fig.11.2(b)], the inlet valve is closed and the pressure starts increasing continuously until the pressure inside the cylinder is above the pressure of the delivery side which is connected to the receiver. Then the outlet valve opens and air is delivered during the remaining upward motion of the piston to the receiver.

✓ To get the practical feel of a compressor unit, the simple view of a reciprocating air-compressor unit showing various external parts is presented in Fig.11.4.

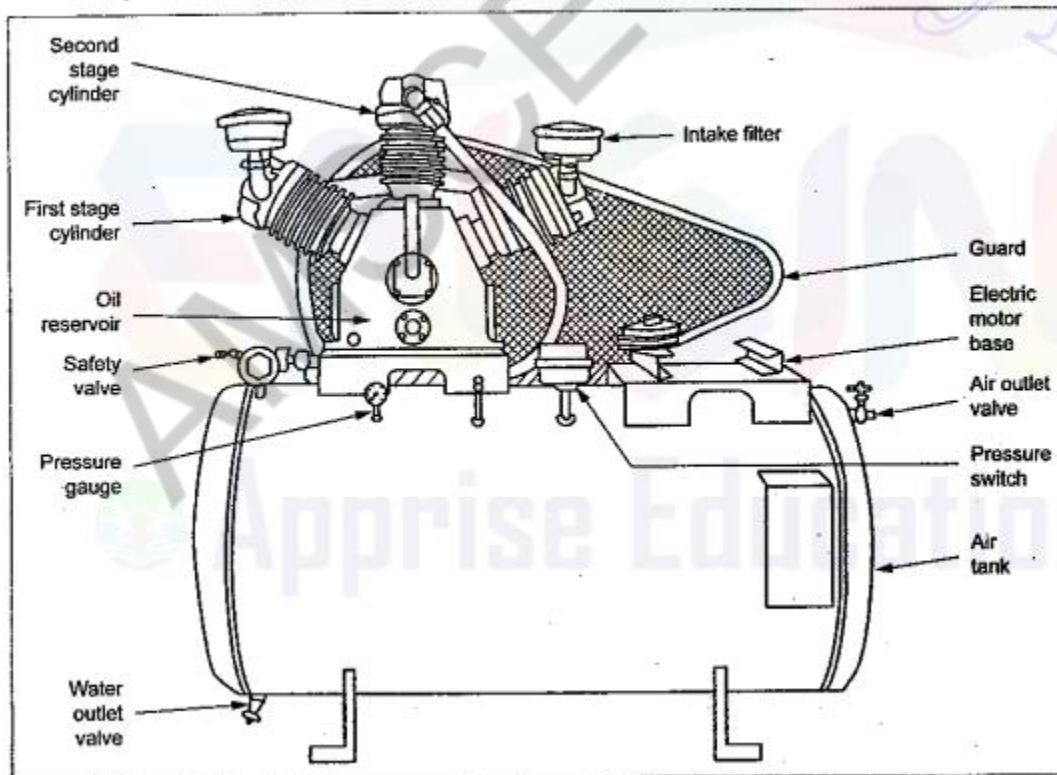

*Fig. 11.4. Parts of reciprocating air compressor*

ii) Discuss the function of FRL unit (Nov/Dec2007) (Ref. Q.No.6)

8. I) What are time delay circuits? Discuss with an example (Nov/Dec2007)

### 9.2.7. Timers

- ✓ Timers, also known as *time-delay relays*, are time delay switches used to control the time duration of a working cycle.
- ✓ Timers are commonly applied in electrical control circuits when a time delay from the instant of actuation to the closing of contacts is required.
- ✓ These timers can be adjusted to change the dwell period for many machining operations. For example, in a drilling machine operation the timers provide a dwell, which allows the drill to pause for a predetermined time at the end of the stroke to remove the chips.
- ✓ The symbolic representation of the timers is shown in Fig.9.8.
- ✓ Fig.9.8(a) shows a normally open switch when energized closes after a predetermined time interval. Fig.9.8(b) shows a normally closed timer switch that is time opened when energized. Fig.9.8(c) shows the normally open timer switch that is timed when

de-energized. Fig.9.8(d) shows the normally closed timer switch that is time close when de-energized.

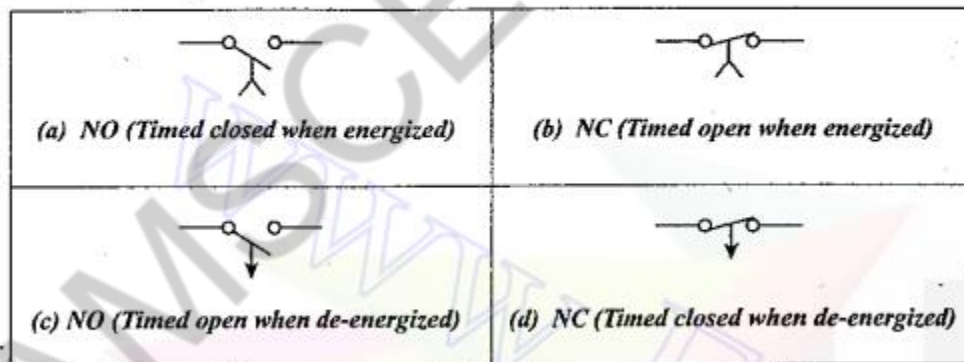

Fig. 9.8. Electrical timer symbols

ii) What are the selection criteria for pneumatic components? (Nov/Dec2007)

The various pneumatic components for a pneumatic system are selected based on the following criteria :

1. Work output required.
2. Maximum fluid pressure used in the system.
3. Speed of operation.
4. Life of the system.

9. I) What are advantages of fluidic system (Nov/Dec 2007)

**15.2.2. Advantages of Fluidic Control Systems**

The basic characteristics of using fluids to control themselves offer various advantages over the conventional alternate control methods. Some of the important advantages of fluidic control systems are given below :

1. Fluidic devices offer exceptional thermal and physical stability and ruggedness, when compared to electronic control systems. (Through the electronic logic control systems are widely used, they are affected by temperature, shock, vibration, and radiation.)
2. Fluidic devices are completely insensitive to radiation, even of extremely high levels.
3. Fluidic devices are not affected by severe vibration and shock.
4. Unlike hydraulic and pneumatic control components, fluidic devices are not susceptible to wear and tear. In other words, since fluidic components do not have any moving parts, they virtually do not wear out.
5. Simpler construction and easier maintenance.
6. Highly reliable functionality.
7. Relatively low cost.
8. Interfacing capability can be easily accomplished with fluidics. Fluidic components can be interfaced to control pneumatic, electrical, or other systems.
9. Since air is normally used as the working fluid within these devices, there are no problems of electrical noise, vibration, fatigue and contact contamination.
10. Since there is no arcing or sparking of switching elements, circuits employing fluidic devices can be operated quite safely in highly explosive or other dangerous environments.

ii) Explain the function of an air pressure regulator with neat sketch (April/May2008)

**11.8.1. What are Air Pressure Regulators ?**

- ✓ **Function :** The function of the air pressure regulator is to regulate the pressure of the incoming compressed air so as to achieve the desired air pressure at a steady condition.
- ✓ The compressed air leaving the compressor should be properly prepared before it goes into the circuit. The air should have the proper operating pressure for the circuit. Improper fluctuating pressure level in the piping system can adversely affect the operating characteristics of the system components such as valves, cylinders, etc. Therefore, air pressure regulators are fitted to ensure the constant supply pressure irrespective of the pressure fluctuations in the compressor unit.

It consists of diaphragm, valve, main and dampening springs, etc. Usually the diaphragm is made of oil-resistant synthetic rubber with a nylon cloth reinforcements.

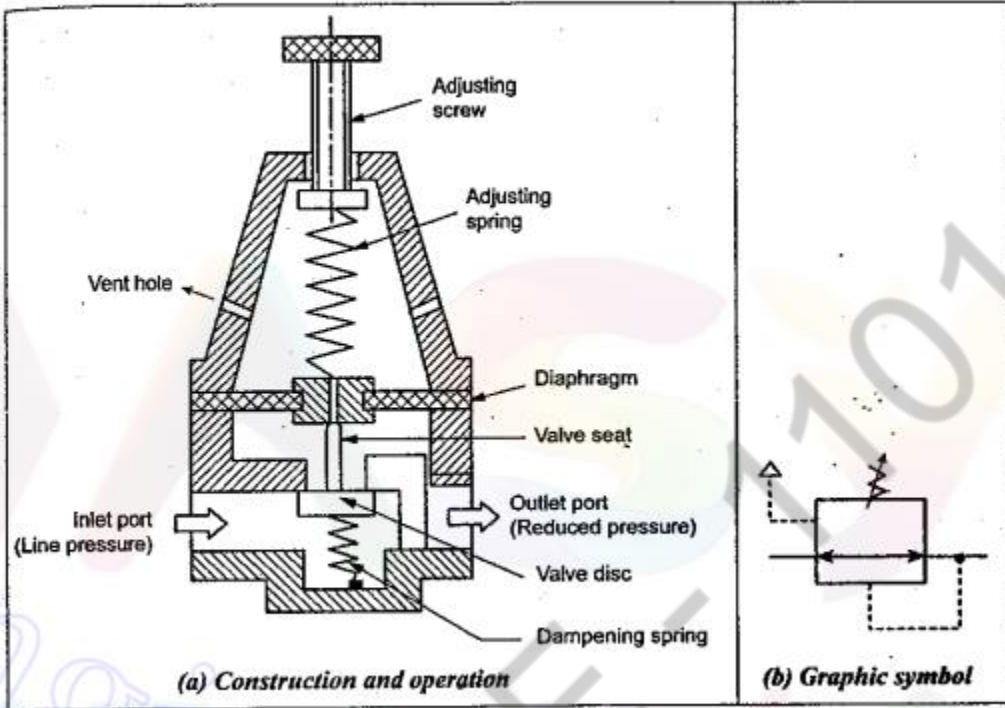

Fig. 11.9. Typical air pressure regulator

### 11.8.3. Operation

The diaphragm allows the proper amount of movement for opening and closing at the valve seat. When the adjusting screw is in the fully retracted position, the valve is closed. When the adjusting screw is turned to compress the adjusting and dampening springs, the valve is opened. Thus the air is allowed from inlet port to the outlet port.

The pressure of the outlet air depends upon the size of the valve opening that is maintained. This is determined by the compression of the adjustable spring. Higher the spring compression, more will be the amount of opening and hence more the pressure and vice versa.

The vent-holes are provided to let out the undesirable excessive outlet pressure, if any, into the atmosphere. The dampening spring is provided to act as a dampening device needed to stabilize the pressure.

10. I) What is meant by ladder programming? ( April/May 2008)

- ✓ The basic form of programming commonly used with PLCs is *ladder programming*.
- ✓ PLC programming based on the use of ladder diagrams involves writing a program in a similar manner to drawing a switching circuit.
- ✓ The ladder diagram consists of two vertical lines representing the power lines. Circuits are connected as horizontal lines. *i.e.*, the rungs of the ladder, between these two verticals.

ii) Draw the basic standard symbol that are used in ladder diagram, Also show rungs in a ladder diagram. (April/May 2008)

9.3.3. Details of a Ladder Diagram

Consider a typical ladder diagram as shown in Fig.9.9 for some application.

- ✓ **Legs and Rungs** : In Fig.9.9, the two vertical electrical power supply lines are called 'legs', and the horizontal lines containing electrical components are called 'rungs'.
- ✓ In ladder diagrams, always the power is connected to the left leg and the ground is connected to the right leg.
- ✓ It should be noted that always the switches should be shown in their unactuated (*i.e.*, open) mode in the ladder diagrams.

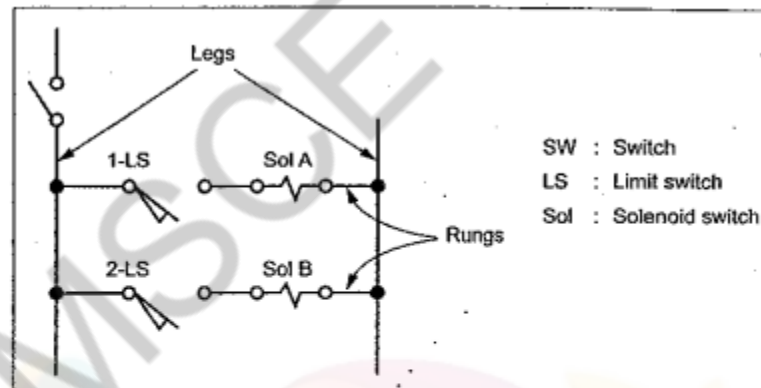

Fig. 9.9. Typical ladder diagram

- ✓ Since the electric circuit diagram resembles to a ladder, this diagram is called a 'ladder diagram'.
- ✓ **Uses** : Ladder diagrams provide a circuit designer with a practical means to examine input process and output functions to quickly plan the circuit layout design for a particular hydraulic or pneumatic application.

## 11. Draw and explain the function of an air filter (May/June 2009)

### 11.7. AIR FILTERS

#### 11.7.1. What are Air Filters ?

- ✓ **Functions :** The function of air filters is to remove all foreign matter and allow dry, clean air to flow without restriction to the regulator and then on to the lubricator.
- ✓ Filters are available in wide ranges starting from a fine mesh wire cloth (which only strains out heavier foreign particles) to elements made of synthetic materials (which are designed to remove very small particles).
- ✓ Usually in-line filter elements can remove contaminants in the 5 to 50  $\mu\text{m}$  range.

#### 11.7.2. Factors Affecting Selection of Filters

While selecting the filters, the following factors at least should be taken into account :

1. Size of particles to be filtered from the system.
2. Capacity of the filter.
3. Accessibility and maintainability.
4. Life of the Filter.
5. Ability to drain the condensate.

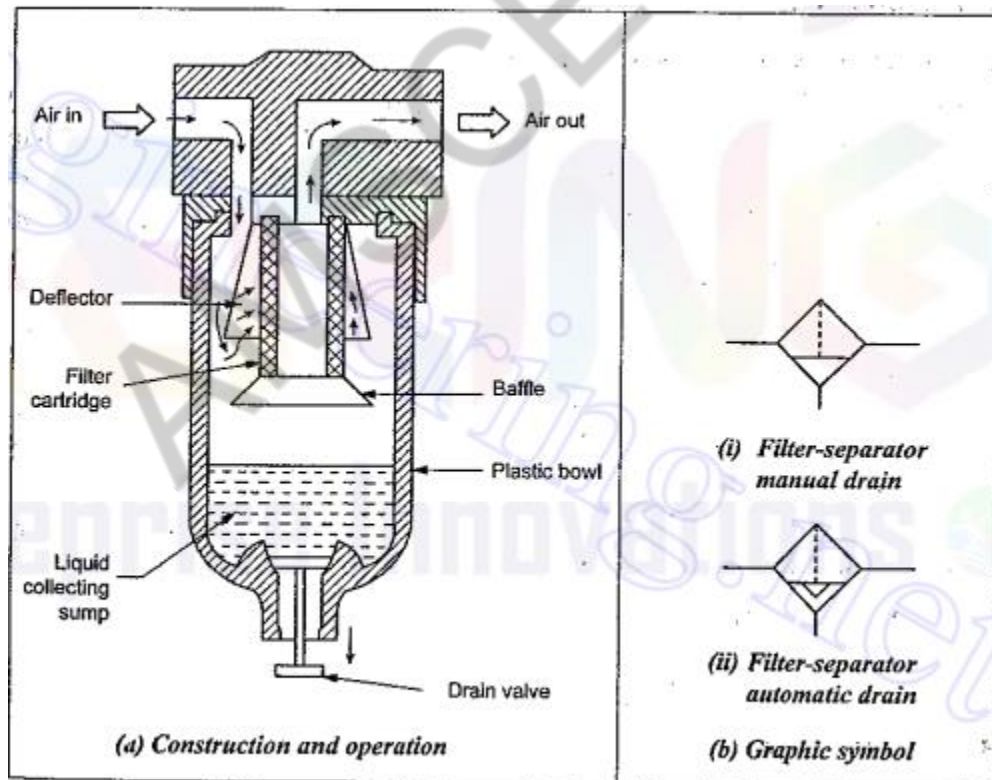

Fig. 11.8. Typical air-filter system



It consists of the filter cartridge, deflector, plastic bowl, baffle, water drain valve, etc.

#### 11.7.4. Operation

The air to be filtered is allowed downward with a swirling motion that forces the moisture and the heavier particles to fall down. The deflector used in the filter mechanically separates the contaminants before they pass through the cartridge filter. The filter cartridge provide a random zig-zag passage for the air flow. This type of air flow arrests the solid particles in the cartridge passage.

The water vapour gets condensed inside the filter and is collected at the bottom of the filter bowl. Also heavier foreign particles that are separated from the air are collected at the bottom of the bowl. Then the accumulated water and other solid particles at the bottom of the filter bowl are drained off with the use of an on-off drain valve located at the bottom of the filter bowl.

#### 11.7.5. Graphic Symbol

Fig.11.8(b) shows the graphic symbol for an air-filter.

ii) Draw and explain the function of pneumatic check valve (May/June2009)

### 12.3. CHECK VALVES

#### 12.3.1. What are Check Valves ?

- ✓ Check valves are the most commonly used and the simplest type of directional control valves.
- ✓ **Functions :** The check valves are used :
  - (i) to allow free flow of compressed air in only one direction, and
  - (ii) to prevent any flow of compressed air in the opposite direction.
- ✓ Since check valves block the reverse flow of the fluid, they are also known as *non-return valves*.

#### 12.3.2. Construction and Operation

The sectional view and ANSI symbol of pneumatic check valve are shown in Fig.12.1(a). The construction and operation of a typical pneumatic check valve is illustrated in Figs.12.1(b) and (c).

As shown in Fig.12.1(b), when flow is in the forward direction, the compressed air pressure pushes the disk seal and thus the valve allows free flow. Instead, if flow is attempted

in the opposite direction as shown in Fig.12.1(c), the compressed air pushes the disk seal in the closed position. Hence no flow is permitted in opposite direction.

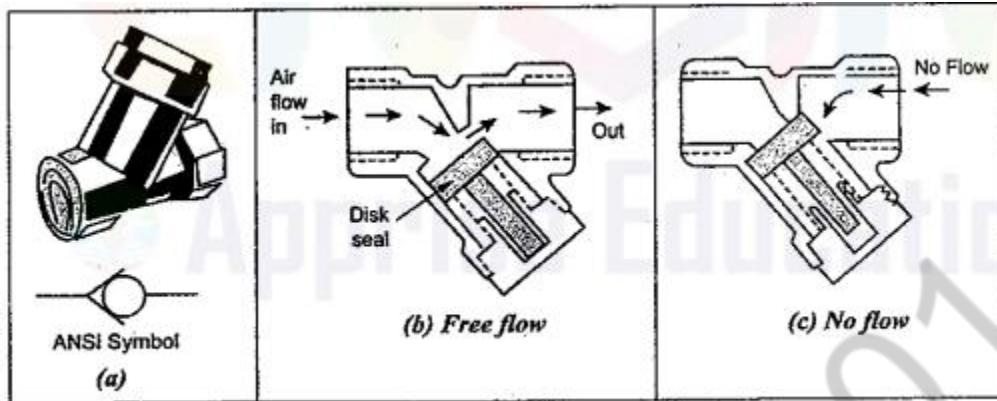

Fig. 12.1. Pneumatic check valve

**12. Design a pneumatic circuit for the following sequence using cascade method  
A+B+B-A-C+C- (May/June2009)**

☺ **Solution :** The steps involving during the design of this circuit is explained as below :

**Step 1 :** Given sequence is  $A^+ B^+ B^- A^- C^+ C^-$

**Step 2 :** The given sequence can be initially splitted into three groups as

$$\frac{A^+ B^+}{I}, \frac{B^- A^- C^+}{II}, \frac{C^-}{III}$$

In order to keep the number of groups minimal, the  $C^-$  can be assigned to group I. So the ideal grouping is as follows :

$$\frac{C^- A^+ B^+}{I}, \frac{B^- A^- C^+}{II}$$

**Step 3 :** Number of pressure lines = Number of groups = 2

**Step 4 : Selection of valves :**

(i) Number of pilot operated 4/2 DC valve = Number of cylinders = 3

Thus three cylinder actuation—VA, VB, VC—are provided.

(ii) Number of limit valves =  $2 \times$  Number of cylinders =  $2 \times 3 = 6$

Thus six limit valves— $a_0, a_1, b_0, b_1, c_0, c_1$ —are provided.

(iii) Number of cascade (or group changing) valves =  $\left\{ \begin{array}{l} \text{Number of} \\ \text{groups} \end{array} \right\} - 1 = 2 - 1 = 1.$

So for this circuit, only one cascade valve is sufficient.

**Step 5 :** The valve connections are made as follows :

- (i) The cascade valve CV is shifted to its left envelop flow path configuration so that the pressure manifold to group I is pressurized. First line I is connected directly to the pilot line (-) of 4/2 DC valve VC. So retraction of C (C-) starts when group I is pressurized.

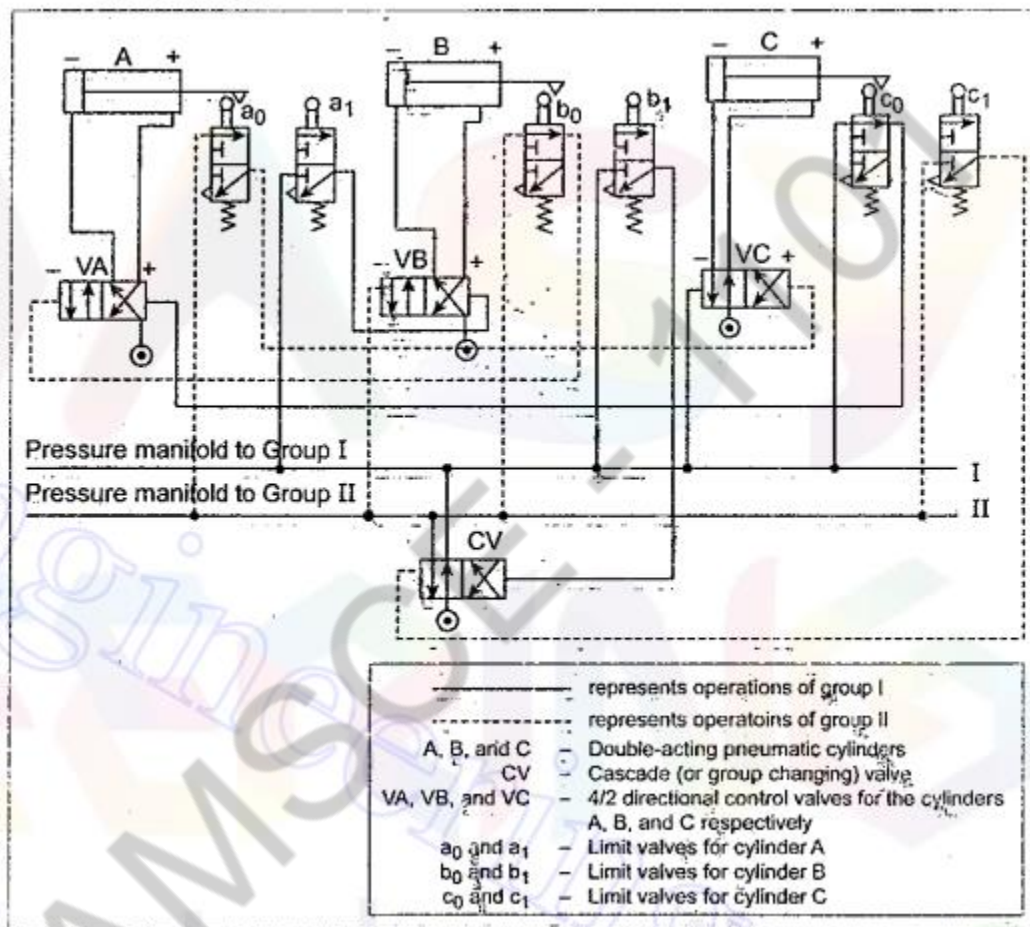

At the end of retraction of C, the limit valve  $c_0$  is actuated. Now the pressure from manifold line I passes through  $c_0$  to the pilot line (+) of 4/2 DC valve VA. As a result, cylinder A extends ( $A^+$ ) and actuates limit valve  $a_1$ . Pressure then passes from manifold line I through  $a_1$  to the pilot line (+) of 4/2 DC valve VB; this causes cylinder B to extend ( $B^+$ ) and actuates limit valve  $b_1$ . Thus the sequencing of Group I is completed.

As a result, cylinder A retracts ( $A^-$ ) and actuates limit valve  $a_0$ . Pressure then passes from manifold line II through limit valve  $a_0$  to the pilot line (+) of 4/2 DC valve VC; this causes cylinder C to extend ( $C^+$ ) and actuates limit valve  $c_1$ .

- (iii) Now the pressure from limit valve  $c_1$  shifts the cascade valve CV to its left envelop flow path configuration and thus the pressure manifold I is pressurised again. Thus the automating sequencing of  $C^-A^+B^+B^-A^-C^+$  can be achieved.

AMSCCE - 1101

## UNIT V

### PART-A

#### TROUBLE SHOOTING AND APPLICATIONS

##### **1. What is the difference between pressure switch and a temperature switch? Nov/Dec 2012**

Pressure switches open or close contacts based on the system pressure. Temperature switches sense change in temperature and open or close contacts when a predetermined temperature is reached.

##### **2. Define low cost automation? May/June2013**

Low-cost automation is defined as a technology that creates some degree of automation around the existing equipment, tools and methods, using mostly the standard equipment available in the market.

##### **3. What is the use of temperature switch? (April/May2008)**

Temperature switches are used in a variety of industrial and technical processes. If a preset temperature is reached, then the temperature switch opens or closes a corresponding switch contact. Depending on the requirements, mechanical or electronic switches can be used

##### **4. How is the speed of a cylinder controlled in pneumatic system? (Nov/Dec 2009)**

When cylinder piston extends, air behind it is compressed because air can't escape easily. When you tighten the flow control screw, movement of the piston slows down because air is restricted even further. Controls the speed of a cylinder or restricts air flow. Simply turn the needle valve to adjust air speed.

**5. Mention the area in a pneumatic system, which should be given higher importance during maintenance? (Nov/Dec 2009)**

- Always ensure that you have an accurate circuit as well as the functional diagram of the pneumatic system. If any changes are made after installation, ensure that they are made in the directions as well.
- Do take care that the impulse valves of the system is protected from excess of dirt, mechanical shocks and cooling water.
- Imprints of the elements and the units should be accurate and easily visible.
- The valve openings that are given by the manufacturers should only be used.

**6. Do not drill the elements of the system for a new opening. (April/may2015)**

- If you need an additional opening, discuss it with the manufacturer and they might design a custom system for you.
- The service unit of the system should be clearly visible and easy to service. If possible, also ensure that it is placed higher than the other elements.
- Do not increase the throttle that what is needed and specified by the manufacturer.
- If you are dismantling the cylinders or valves, do take care of its sealing materials. Even while assembling them again, ensure that they are properly placed.
- Actuated valves, though appear easy to work with, but are known to cause serious problems. Thus, it is good to ensure that they are controlled in the proper direction and at the required speeds only.

**7. Draw a sketch of a graphical symbol for 3 position 4 ways solenoid energized pilot operated tandem DCV (April/May2010)**

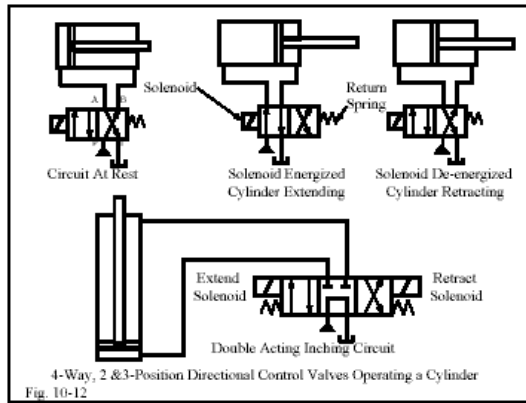

**8. What is meant by automation? (April/may2015)**

Automation of a process plant (or) a flow line is done by means of specially designed machinery and equipments, which represent the highest level of automation. Chemical processing and automated assembly lines are examples of such automation.

**9. What is a power pack? Nov/Dec 2011, Nov/Dec 2012**

A hydraulic power pack is a self-contained unit that consists mainly of a motor, a reservoir and a hydraulic pump. Using fluid to transmit power from one location to another, hydraulic power packs can generate massive amounts of power which can be used to drive hydraulic machinery.

**10. When to use timer and relay? Why?( Nov/Dec2012)**

Their purpose is to control an event based on time. The difference between relays and time delay relays is when the output contacts open & close: on a control relay, it happens when voltage is applied and removed from the coil on time delay relays, the contacts can open or close before or after some time delay

**11. Mention any two rules of pneumatic system in low cost automation (April/May 2005)**

Pneumatic systems are popularly used for low cost automation (LCA) applications due to their low cost, ease of fabrication, and safe operation.

**12. What you understand by single shot sequencing? (April/May 2005)**

By sequencing a number of cylinders, various machining and tooling operations may easily be obtained in a machine. By using sequencing, the cylinders can be actuated one after another in sequences like clamping, drilling, unclamping, etc.

**13. What is power pack? (Nov/Dec2005)**

Power pack consists of a pump, electric motor, reservoir and associated valving assembled to one unit to supply pressurized fluid. They are relatively small in size and provide functions of pressure, direction and flow control within the basic package.

**14. How do you Microprocessor differ from PLC? (Nov/Dec2005)**

The advantages of PLCs over microprocessors are given below :

1. PLCs are rugged and designed to withstand vibrations, temperature, humidity and noise.
2. The interfacing for inputs and outputs is inside the controller.
3. They are easily programmed and have an easily understood programming language.



**15. . What is a Microprocessor? (May/June 2006)**

Microprocessor is the central processing unit (CPU) of a micro-computer. It is the heart of the microcomputer. It is a semiconductor device. It includes arithmetic and logic unit, register arrays, and control circuits on a single chip.

**16. What are the important component of hydraulic power pack(Nov/Dec2006)**

Hydraulic power pack consists of the pump, drive motor, mechanical couplings, oil reservoir, strainers, filters, coolers, etc.

**17. State the role of PLC in fluid power industry. (Nov/Dec2006)**

PLCs are designed as a replacement for hard-wired electro-mechanical relays to control fluid power systems.

**18.What is the use of temperature switch. (Nov/Dec2008)**

A temperature switch is an instrument that automatically senses a change in temperature and opens or closes an electrical switching element when a predetermined temperature point is reached.

**19. What is a step counter? (May/June 2008)**

A step counter is a digital modular counter constructed from stepping units. A stepping unit is built from memory valve and a preswitched AND valve with two inputs.

**20. What is the meaning of the term troubleshooting? (May/June 2008)**

The term troubleshooting means an organized and systematic study of the problem and a logical approach to the difficulty faced in the system

## UNIT-V

### PART-B

1. List out various operating problems associated with pumps, valves and various faults, possible causes and suitable remedy for each problem. (Apr/May2005)

Trouble/Fault	Probable causes	Remedial actions
<b>I. PUMP</b>		
1. Pump delivering insufficient or no oil	Wrong direction of shaft	Must be reversed immediately to prevent seizure and breakage of parts due to lack of oil
	Pump shaft turning too slowly to prime itself	Check minimum speed recommendation and momentarily increase rpm, to rectify
	Clogged strainer or suction pipe line	Clean strainer or suction pipe line. Remove foreign matter
	Strainer capacity insufficient	Replace with a strainer whose capacity is more than twice the maximum flow rate
	Air leak in suction line	Add oil and check oil level in reservoir. Check for leaks and repair
	Faulty rotating part in the pump body	Check by listening to the sound. Remove the cover and check the internal mechanism. Replace, if necessary
	Oil leak in pump casing due to seizure or wear of pump sliding parts	Check the sliding parts
	Low level of oil in the reservoir	Add the oil recommended as per the indicator line
	Oil viscosity too heavy to pick up prime or too light causing excessive slippage	Use oil as per recommendation

Trouble/Fault	Probable causes	Remedial actions
2. Pump developing unstable or zero pressure	Pump not delivering oil for any of the above reasons	Apply the above remedies
	Relief valve setting not high enough	Correct valve setting by using pressure gauge
	Relief valve sticking open	Check relief valve. If necessary, dismantle and clean valve
	Clogged orifice of the relief valve	Overhaul and clean relief valve
	Mis-assembly, mis-connection or mis-operation of various valves in the circuit	Must be corrected
	Faulty performance of various valves or excessive oil leakages in the circuit through actuators and valves etc.	Test each component separately and repair
	Faulty pressure gauge	Check and replace if necessary
	Partially clogged suction line or suction strainer	Clean and remove foreign matter
3. Pump making noise	Misalignment of pump and prime mover	Check and rectify
	Strainer capacity insufficient	Replace with a strainer whose capacity is more than twice the maximum flow rate
	Air leak at pump's suction pipe joints or from shaft packing of the pump	Pour oil on suspected joints while listening for change in sound. If sound stops, tighten the joint
	Air remains in pump casing	Eliminate air through the air breather
	Small size of suction pipe	Replace so that the flow velocity on the suction side will be approximately 0.5 to 1
	Coupling misalignment	Re-align properly
	Pump bolts very loose	Tighten
	Resonance noises in the system	Reinforce by installing supports to eliminate resonance
	Air bubble or too much foam in suction oil.	Check to be certain that the return lines are below oil level and well separated from suction lines.
	Very high viscosity.	Use recommended oil.
Pump running too fast.	Check the recommended maximum speed.	

Trouble/Fault	Probable causes	Remedial actions
4. Pump oil over-heated	Faulty oil cooler	Repair
	Insufficient size of oil reservoir	Increase capacity or install an oil cooler
	Pump pressure too high	Readjust relief valve setting
	Excessive flow velocity	Replace piping
	Seizure of pump's sliding parts	Dis-assemble and repair. Check for foreign matter in oil and see if the pump casing is filled with oil
5. Internal leakage around pump	Shaft packing worn out	Replace
	Top cover packing damaged	Change the packing and apply clamping torque on the cover as per manufacturer's recommendation
6. Excessive wear	Abrasive matter in the hydraulic oil being circulated through	Install an adequate filter or replace oil more often
	Viscosity of oil very low at working conditions	Check pump manufacturer's recommendations or consult your hydraulic engineer
	Sustained high pressure above the maximum pump rating	Check maximum setting of the relief valve
	Misaligned drive or tight belt drive	Check and rectify
	Air recirculation causing chatter in the system	Remove air from the system
7. Breakage of parts inside pump housing	Excessive pressure above maximum pump rating	Adjust relief valve properly
	Seizure due to lack of oil	Check oil level in reservoir and cleanness of strainer and any other possible restrictions in suction lines

#### II. RELIEF VALVES

1. Erratic pressure	Dirt in oil	Clean strainer and flush the system
	Worn poppet or seat	Lap the poppet or replace
	Piston sticking in the main body	Check and rectify

Trouble/Fault	Probable causes	Remedial actions
2. No or low pressure	Vent connection open	Check and rectify
	Balance hole plugged	Check and rectify
	Poppet not seating properly	Check, lap and repair
3. Excessive noise or chatter	High oil velocity	Check and rectify
	Faulty or worn poppet or seat	Check, lap or replace
	Excessive tank line pressure	Check and rectify
	Long vent line or pressure setting too close to that of another valve in the circuit	Check and rectify
	Valve setting too close to the system operating pressure	Set relief valve at least 10 bar higher than the required working pressure of the system
<b>III. DIRECTIONAL CONTROL VALVES (DCVs)</b>		
1. Faulty or incomplete shifting	Worn out control linkage, shift pin, etc.	Check and repair
	Insufficient pilot pressure	Check and rectify
	Burned out solenoid	Check and replace
	Worn spring centering mechanism	Check and replace
2. Cylinder creeping or drifting	Valve spool not centering properly	Check and rectify
	Valve spool not shifting completely	Check and replace
	Valve spool or body worn out	Check and rectify
	Leakage past the piston in the cylinder	Check and overhaul the cylinder
<b>IV. SEQUENCING VALVES</b>		
1. Premature movement of secondary operation	Valve set too low	Check and set it higher
	Excessive load on primary cylinders	Check and adjust accordingly
2. No movement or slow secondary operation	Sequence valve setting too high	Check and adjust again
	Relief valve setting too close to that of sequence valve	Should have at least 10 bar differential
	Valve spool binding in body	Check and repair
<b>V. UNLOADING VALVES</b>		
1. Fails to completely unload pump	Valve setting too high	Set correctly
	Remote pressure setting too low	Adjust properly
	Valve spool binding in body	Overhaul valve

Trouble/Fault	Probable causes	Remedial actions
<b>VI. COUNTERBALANCE VALVES</b>		
1. Will not support load	Valve setting too low	Set properly
	Dirt under integral check valve	Flush the system
	Valve spool and body worn out	Replace worn out parts
	Leakage past the piston in the cylinder	Check and overhaul the cylinder
<b>VII. FLOW CONTROL VALVES</b>		
1. Variation in feed	Sticking hydrostat	Overhaul valve
	Cylinder or motor leakage	Overhaul cylinder or motor
	Change in oil viscosity	Check and replace oil
	Inproper pressure drop across valve	Adjust correctly
	Inadequate lubrication of machine parts	Check and do the necessary rectifications
<b>VIII. REMOTE FLOW CONTROL VALVES</b>		
1. External leakage	Back pressure in drain line or defective seals	Drain directly to reservoir or replace seals
2. Feed rate variation	Hydrostatic pressure compensator inoperative or sticking hydrostat	Clean valve and flush system. Polish hydrostat and metering spool. Replace defective seals
3. Maximum flow not obtainable	Contaminants in the throttling orifice. Metering spool binding or not shifting fully. Insufficient voltage in torque motor	Clean valve. Check torque motor coils and input current. Re-align properly
4. Check valve-inoperative	Dirt lodged between the mating faces or finished faces	Disassemble and flush thoroughly

**2.i) Explain the applications of hydraulic and pneumatic systems for low cost automation with suitable examples. (Apr/May2005)**

**Applications of hydraulic systems as follows**

Examples of equipment that use hydraulic fluids include excavators and backhoes, hydraulic brakes, power steering systems, transmissions, garbage trucks, aircraft flight control systems, lifts, and industrial machinery. Hydraulic systems will work most efficiently if the hydraulic fluid used has zero compressibility

**Applications of Pneumatic systems as follows**

Processing industries, such as chemical, petrochemical, food processing, textiles, paper, etc. Used in the brake system of automobiles, railway coaches, wagons and printing presses.

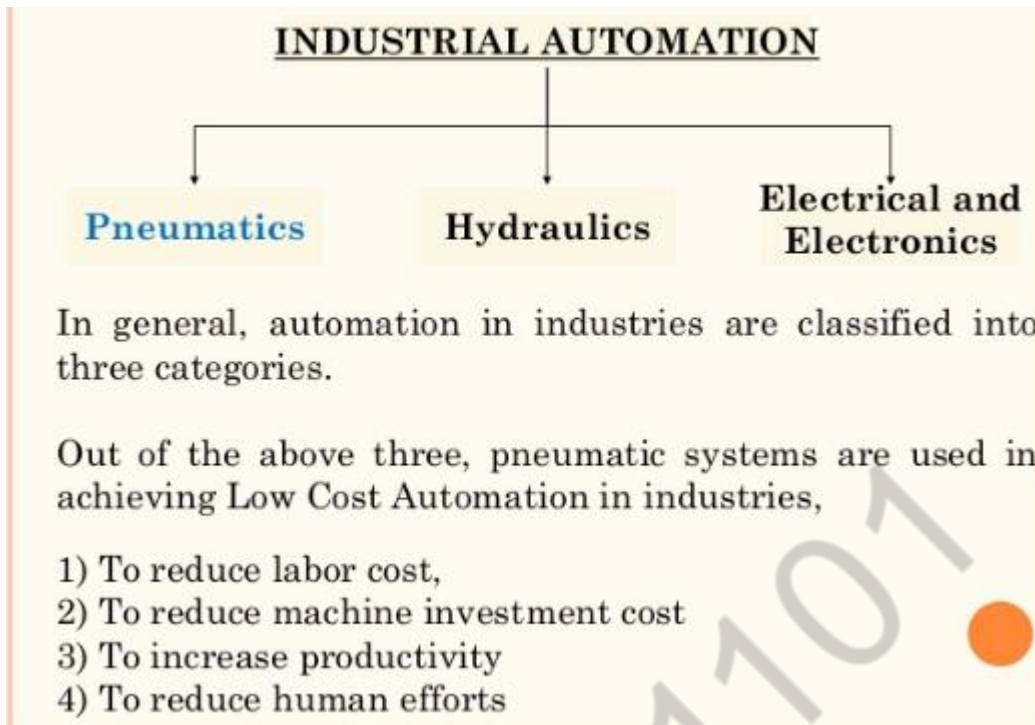

**ii) Write a note on power packs. (Apr/May2005)**

Power pack consists of pump, electric motor, reservoir, and associated valving assembled to one unit to supply pressurized fluid. They are relatively small in size and provide functions of pressure, direction and flow control within the basic package.

**3.i) Briefly explain the maintenance requirements for hydraulic power packs. (May/June2006)**

Hydraulic power packs need regular maintenance to extend their life and to allow safe operation. Maintenance includes checking the tubing for dents, cracks or other problems, changing the hydraulic fluid and checking the reservoir for rust or corrosion.

**ii) Explain the principle of low cost automation. (May/June2006)**

The main aim of Low Cost Automation is to increase Productivity and quality of products and reduce the cost of production, and not reduce labor. Even the lower level technologies can be made highly productive by automation at low cost and in simple form.

**4.i) What are the factors considered during the installation of pneumatic systems. (Nov/Dec2007)**

The various factors to be considered during the installation of pneumatic systems are given below:

1. *Installation of FRL unit*—installed upstream from the other components.
2. *Installation of cylinder*—properly mounted and perfectly aligned, it should be ensured that the cylinders are properly lubricated.
3. *Installation of pipelines*—adequate filter between the main and the circuit to be ensured, water trap is to be fitted at the end of each branch line, piping should be sloped away from the compressor.
4. *Installation of compressor*—compressor intake should be from the outside air, open end of intake pipeline screened to prevent rain and dirt entering.

ii) List out various operating problems associated with pumps, valves and various faults, possible causes and suitable remedy for each problem (April/May2008)

Ref Question no 1 (Apr/May2005)

5. Discuss any eight common problems and their remedies in pneumatic circuits. (Nov/Dec2009)



Trouble/Fault	Probable causes	Remedial actions
<b>I. COMPRESSORS</b>		
1. Unusual noise	Leaking cylinder valve	Adjust and stop leakage
	Loose belt in compressor wheel, motor pulley	Adjust the belt as recommended
	Motor with excessive end play in shaft	Adjust the end play
	Carbon on top of the piston	De-carbonise
	Leaking, broken or worn out constant speed unloader parts	Adjust or replace
	Valve seats worn	Recondition valve seat
	Worn or scored connecting rod, piston pin or crank pin bearings	Recondition the connecting rod, replace or condition gudgeon pin and crank pin bearings
	Defective ball bearings on crank shaft or on motor shaft	Replace bearings
	Loose motor fan	Tighten the motor fan
	Cylinders or pistons scratched, worn or scored	Rebore cylinder and replace piston
2. Inadequate performance	Dirt in suction filter	Clean filtering plate and filter disc. Do not use gasoline for danger of explosion
	Defective sealing of cylinder head	Mount fresh packing of the cylinder head
	Valve interference through dislocated valve seat and valve guide	Exchange valve insert plate
	Worn out pistons and piston rings as well as worn out cylinder	Exchange piston with rings and also the cylinder if necessary
	Piston rings broken or not sealed	Replace piston rings as per manufacturer's instructions
	End gap not staggered in grooves	Stagger the end gaps, make the rings free in the grooves
	Rough, scratched or excessive	Replace

Trouble/Fault	Probable causes	Remedial actions
<b>II. FILTERS</b>		
1. Excessive pressure drop through filter	Dirty filter element	Replace filter element
	Filter is undersized	Consult manufacturer's flow charts; consider both body, size and port sizes when specifying
2. Contaminants carried through the filter	Elements omitted during servicing	Replace missing elements
	Elements not tightened enough	Tighten elements to prevent bypass
	Broken elements	Replace broken elements
	Element too coarse	Replace with finer graded elements
	Broken end cap from increased pressure drop caused by dirt build-up on entry side	Install standard particle filter ahead of the coalescing filter
3. Moisture in downstream air	Sump of filter bowl has collected too much water and water is re-entering the system	Drain bowl or install automatic drain
	Installation is wrong	Correct installation
	Location is incorrect : filter too close to the after cooler or too high in the plant ceiling	Relocate filter or install a dryer
	Body size is too large, causing low velocity and inefficient operation	Consult manufacturer's data
	Dew point of air is too high	Install a dryer
4. Plastic bowl crazed and breaking	Incompatible chemicals in contact with the plastic	Unless exact cause can be identified, substitute with metal bowls
	Excessive temperatures,	Unless damaging agent can be identified, substitute with metal bowls
<b>III. REGULATORS</b>		
1. Regulator cannot reach high set point	Pressure gauges are inaccurate	Ensure that gauge calibration is a regular maintenance function
	Insufficient upstream pressure	Measure and compare inlet pressure with outlet pressure
	Incorrect control spring range	Check model number for type used and replace

Trouble/Fault	Probable causes	Remedial actions
	Leakage in downstream circuit	Check fittings, valves, cylinders and regulators, correct as required
	Incorrect adjusting technique	To achieve reduced pressure, turn handle counter-clockwise below desired set point, then clockwise back up
2. Set point pressure becomes too high	External loads imposing a higher pressure	Use pressure relief valves, circuit changes or a venting regulator
	Leakage from inlet side : worn out poppet seal, seat or balancing seal	Check for leakage and replace parts as necessary
	Non-venting regulator can aggravate pressure increase from other causes	Replace with venting regulator
3. Air often escaping from vent hole	External loads imposing a higher pressure	Use pressure relief valves, circuit changes or a ventilating regulator
	Leakage from inlet side : worn out poppet seal, seat, or balancing seal	Check for leakage and replace parts as necessary
4. Pressure too low when air is flowing	Incorrect adjusting technique	To achieve reduced pressure, turn handle counter-clockwise below the desired set point then clockwise back up
	Setting altered through vibration	Re-position adjustments and use locking features to secure position
	Leakage in downstream system	Check connections, component seals and correct as required
	Flow requirement is too high for regulator rating and/or plumbing	Install a larger regulator and/or larger plumbing

6. i) What are the factors considered during the installation of pneumatic systems. (Nov/Dec2011)

#### Cost

When the SS body disposable cylinder was developed, many people questioned the viability of a non-repairable product. This product has not only succeeded, it has also revolutionized the market. Because of its low cost and ease of replacement, many organizations opted to replace many traditional steel, aluminum and brass body cylinders that could be repaired. While these pneumatic cylinders are the most cost-effective choice and easiest to use, they do have limitations that make them less-than-ideal for certain applications.

#### Space

Some applications require short cylinders, not allowing for the entire cylinder body to be much longer than its stroke. For these applications, compact or “pancake” cylinders available with round bodies or shaped aluminum extrusions are ideal. These cylinders use thin heads, caps and pistons. Short bearing surfaces keep cylinder length to a minimum. Because of their size, these pneumatic cylinders typically don’t resist side loads well and are not available in long stroke lengths. They are often used in clamping applications where space is at a premium.

### **Side Load**

Cylinders are designed to provide force on one axis. However, many applications experience forces that act on multiple axes, and cylinders must be able to operate at full capacity while resisting these lateral forces. The most common force attributed to pneumatic cylinder failure is side load. Side load consists of a force applied to the cylinder that is perpendicular to the active axis.

Certain types of cylinders are able to better withstand side load because they have longer bearing surfaces for the rod, longer pistons or a greater distance between pistons and the end of the rod bearing surfaces. Tie rod cylinders and the aluminum extruded version of square body pneumatic cylinders are more robust and better suited to resist side load. They can be built with stop tubes, which aid them in overcoming side load by increasing the distance between pistons and rod bearings surfaces, but add to overall cylinder length.

If you are looking to compensate for side load with lighter-duty cylinders, add guides parallel to the rod, which will absorb side load forces and allow for use in these applications.

### **Serviceability**

Many lower cost cylinders available today are not built to be repaired. The crimped body disposable cylinder cannot be serviced, but low cost and versatility mean that it is easier to simply replace them rather than repair them. The ability to repair a cylinder and put it back into service quickly, however, is a great advantage in high-use MRO facilities. Hard cylinder components typically last through several seal changes, meaning that the ability to repair a cylinder can provide long-term benefits.

### **Cycles**

The number and type of cycles that cylinders experience are critical factors in determining the appropriate cylinders to use in your applications. High-cycle systems can wear out cylinder seals prematurely; as a result, high-cycle seals have been developed to extend cylinder life. Additionally, cylinders that reach the end of their strokes in normal system cycles experience reductions in life cycle resulting from continual piston impact absorption by these cylinders. To remedy this problem, cylinders are offered with cushions and bumpers to reduce force and extend cylinder life.

## Durability

As the performance of aluminum and plastic cylinders have improved, people are opting to convert their steel pneumatic cylinders to ones made of these new materials. There are still applications, however, that demand the durability and serviceability that steel body cylinders provide. In heavy-duty applications such as those found in steel mills and foundries, long life provided by steel cylinders far outweighs any weight or cost savings found in lighter-duty materials. It is always best to process cautiously when deciding whether to replace steel with lighter-duty materials which many not always provide expected product life or serviceability in critical applications.

## Application

The environment in which cylinders operate may require specific types of cylinders. Some pneumatic systems run on lubricated air, which consists of in-line components that add oil mist to compressed air. This oil lubricates seals in valves and cylinders and reduces wear on elastomeric seals as they rub against cylinder walls or rods. Today, many cylinders and seals are matched to the type of compressed air that will be used in their respective systems.

## 7. Explain the installation procedure for various hydraulic systems and its maintenance procedure. (May/June 2013)

Lack of maintenance of hydraulic systems is the leading cause of component and system failure yet most maintenance personnel don't understand proper maintenance techniques of a hydraulic system. The basic foundation to perform proper maintenance on a hydraulic system has two areas of concern. The first area is Preventive Maintenance which is key to the success of any maintenance program whether in hydraulics or any equipment which we need reliability. The second area is corrective maintenance, which in many cases can cause additional hydraulic component failure when it is not performed to standard.

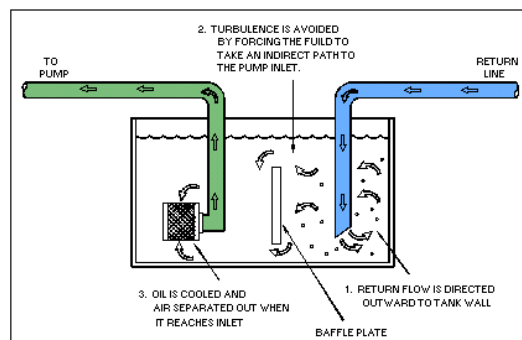

## **Preventive Maintenance**

Preventive Maintenance of a hydraulic system is very basic and simple and if followed properly can eliminate most hydraulic component failure. Preventive Maintenance is a discipline and must be followed as such in order to obtain results. We must view a PM program as a performance oriented and not activity oriented. Many organizations have good PM procedures but do not require maintenance personnel to follow them or hold them accountable for the proper execution of these procedures. In order to develop a preventive maintenance program for your system you must follow these steps:

A list of Preventive Maintenance Task for a Hydraulic System could be:

1. Change the (could be the return or pressure filter) hydraulic filter.
2. Obtain a hydraulic fluid sample.
3. Filter hydraulic fluid.
4. Check hydraulic actuators.
5. Clean the inside of a hydraulic reservoir.
6. Clean the outside of a hydraulic reservoir.
7. Check and record hydraulic pressures.
8. Check and record pump flow.
9. Check hydraulic hoses, tubing and fittings.
10. Check and record voltage reading to proportional or servo valves.
11. Check and record vacuum on the suction side of the pump.
12. Check and record amperage on the main pump motor.
13. Check machine cycle time and record.

Preventive Maintenance is the core support that a hydraulic system must have in order to maximize component and life and reduce system failure. Preventive Maintenance procedures that are properly written and followed properly will allow equipment to operate to its full potential and life cycle. Preventive Maintenance allows a maintenance department to control a hydraulic system rather than the system controlling the maintenance department. We must control a hydraulic system by telling it when we will perform maintenance on it and how much money we will spend on the maintenance for the system. Most companies allow the hydraulic system to control the maintenance on them, at a much higher cost.

AMSCE - 1101