

**AALIM MUHAMMED SALEGH COLLEGE OF ENGINEERING, CHENNAI-55**  
**DEPARTMENT OF ELECTRONICS AND COMMUNICATION ENGINEERING**  
**MODEL EXAMINATION –APRIL'14**  
**EC2255-CONTROL SYSTEMS**

SEM: IV Duration: 3 hrs

DATE:

Max Marks: 100

Answer all the questions

**Part A (10 x 2=20)**

1. What is meant by 'block diagram' of a control system? What are the basic components of a block diagram?
2. Give the comparisons between the open loop and closed loop systems
3. What is meant by peak overshoot and settling time?
4. List the advantages of generalized error coefficients.
5. Write a MATLAB command for plotting Bode diagram  $\frac{Y(s)}{U(s)} = \frac{4s+6}{s^3+3s^2+8s+6}$
6. What is meant by corner frequency in frequency response analysis?
7. Using Routh criterion, determine the stability of the system represented by the characteristic equation  $s^4 + 8s^3 + 18s^2 + 16s + 5 = 0$ . Comment on the location of the roots of characteristics equation.
8. The damping ratio and natural frequency of oscillation of a second order system is 0.5 and 8 rad per sec respectively. Determine the resonant peak and resonant frequency.
9. What are the advantages of state space analysis.
10. What is meant by quantization?

**Part B (5 x 16 =80 marks)**

11. (a) (i) Consider the mechanical system shown below. Identify the variables and write the Differential equations (6)

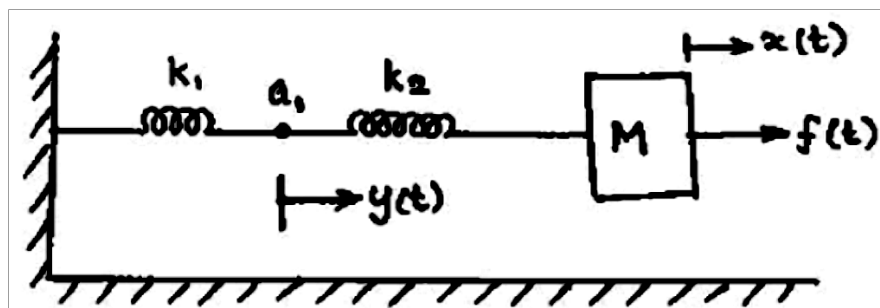

(ii) Draw the torque- voltage electrical analogous circuit for the mechanical system shown in fig2 (4)

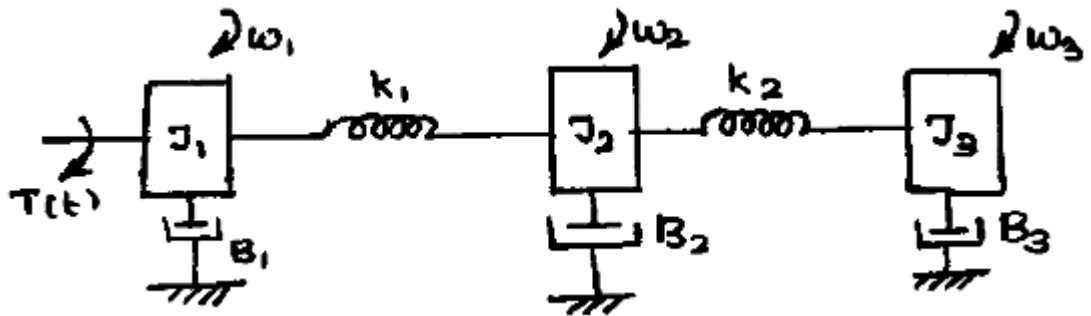

(iii) Obtain the transfer function of the following electrical network.(6)

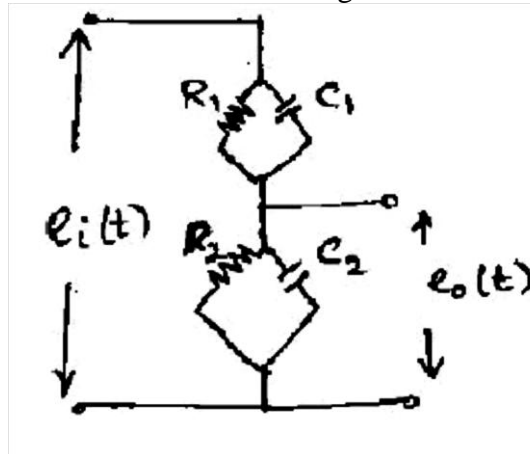

OR

(b) (i) Construct Signal Flow Graph for the block diagram shown below and obtain the overall transfer function(8)

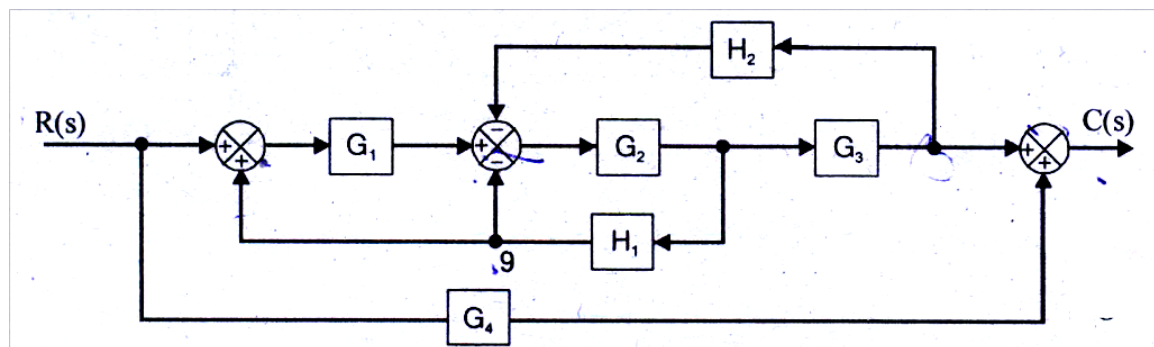

(ii) For the block diagram shown in fig determine the overall transfer function using block reduction rules (8)

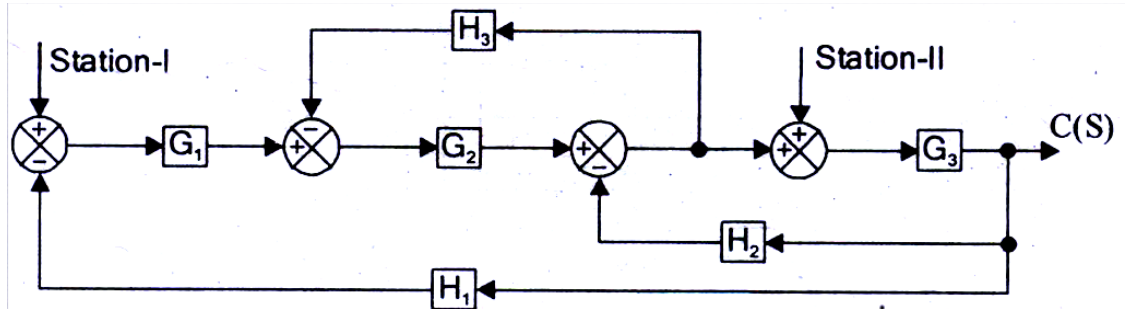

12. (a) (i) Derive an expression for steady state error of a closed loop control system(6)  
(ii) The closed loop transfer function of a second order system is given by  $T(s) = \frac{100}{s^2+10s+100}$ . Determine the damping ratio, natural frequency of oscillation, rise time, settling time and peak overshoot(10)

OR

- (b) (i) Discuss the effect of derivative control on the performance of second order system.(8)  
(ii) The figure shows PD controller used for a system

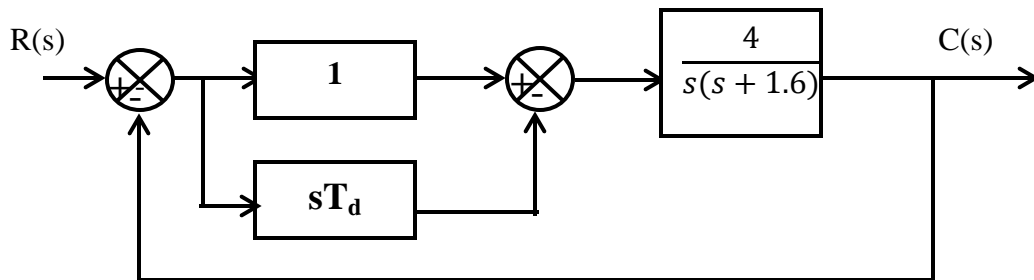

Determine the value of  $T_d$  so that system will be critically damped. Calculate its settling time. (8)

13. (a)(i) Sketch the Bode magnitude plot for the transfer function  $G(s) = \frac{100(1+0.1s)}{(1+0.01s)(1+s)}$ . (8)

(ii) The open loop transfer function of a unity feedback system is given by

$$G(s) = \frac{1}{s^2(1+s)(1+2s)}$$

Sketch the polar plot. (8)

**OR**

(b) Draw the pole- zero diagram of a lead compensator. Propose lead compensation using electrical network. Derive the transfer function. Draw the Bode plot (16)

14. (a) (i) Determine the range of K for stability of unity feedback system whose open loop transfer

function is  $G(s) = \frac{K}{s(s+2)(s+4)}$  using Routh stability criterion. (6)

(ii) Sketch the Nyquist plot for a system with open loop transfer function

$$G(s)H(s) = \frac{K(1+0.4s)(s+1)}{(1+8s)(s-1)}$$

And determine the range of K for which the system is stable.

**OR**

(b) (i) Draw the root locus for the open loop transfer function of a unity feedback control system

given below  $G(s)H(s) = \frac{K}{s(s+1)(s+3)}$  and determine

i. The value of K for  $\zeta = 0.5$

ii. The value of K for marginal stability

iii. The value of K at  $S = -4$  (12)

(ii) Discuss the location of poles for stability (4)

15. (a)(i) Find the state variable equation for a mechanical system (spring- mass-damper system) shown below. (8)

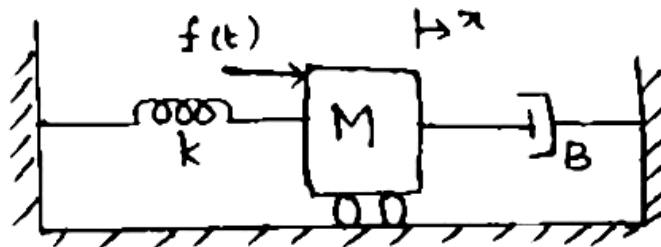

(ii) Determine the transfer function of the state space model : (8)

$$A = \begin{bmatrix} -3 & 1 \\ 0 & -1 \end{bmatrix}, B = \begin{bmatrix} 1 \\ 1 \end{bmatrix} \text{ and } C = [1 \quad 1], D = 0$$

OR

(b)(i) A sampled data control systems is shown in figure below:

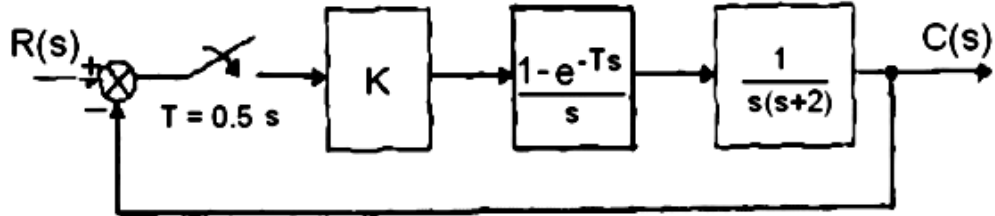

Find the open loop transfer function , if the controller gain is unity with sampling time 0.5 seconds (10)

(ii) Find the controllability of the system described by the following equation: (6)

$$[\dot{X}] = \begin{bmatrix} -1 & -1 \\ 2 & -1 \end{bmatrix} \begin{bmatrix} X_1 \\ X_2 \end{bmatrix} + \begin{bmatrix} 0 \\ 1 \end{bmatrix} U(t)$$

\*\*\*\*\*